

ECN 16443-1002-01 Issue 2

A

B

C

D

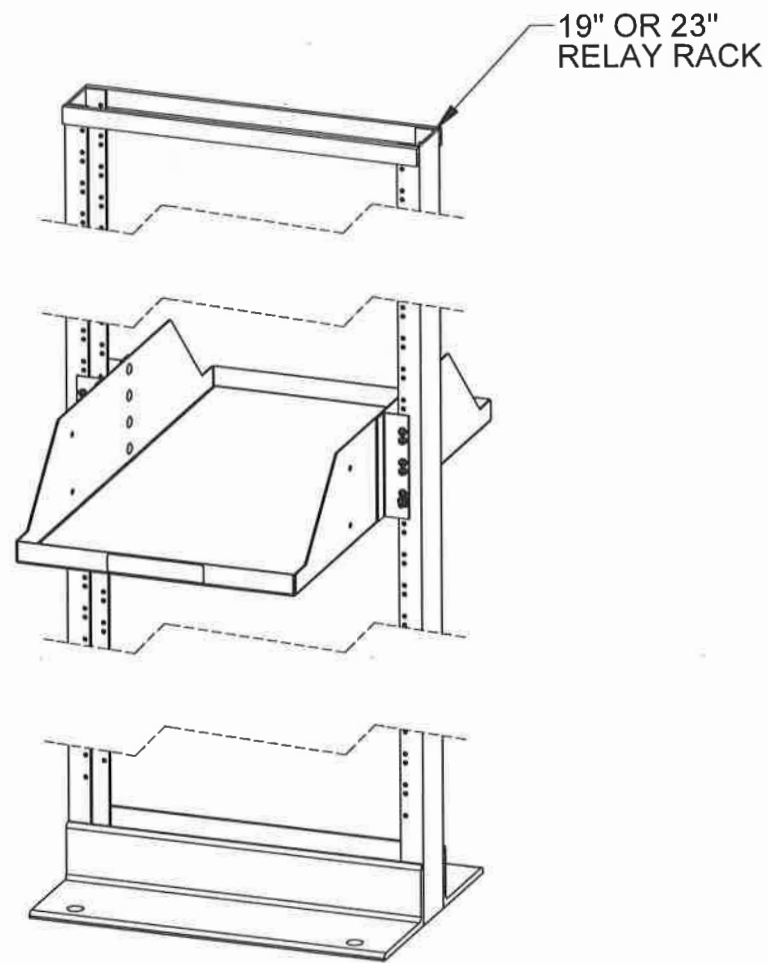

19" OR 23"  
RELAY RACK

SIZE OF BATTERY  
TRAY MAY VARY

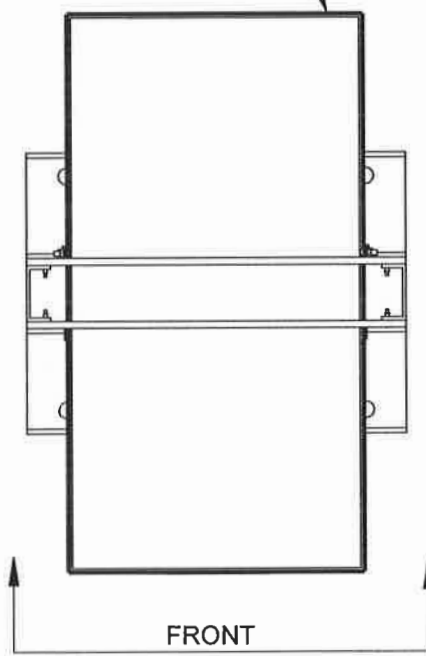

TOP VIEW

ITEM NO.	DESCRIPTION	QTY
0010	BATTERY TRAY	1
0020	BRACKET	2
0400	LABEL, LOGO	1
0500	BOLT, CARRIAGE	8
0501	LOCKWASHER, PAINT BREAK	2
0502	NUT	8
0503	SCREW	24
0504	LOCKWASHER, PAINT BREAK	4
1000	INSULATED RUBBER SHEET	1

BATTERY AND TRAY CONFIGURATION TABLE		
Battery	Battery tray Part #	Rack Size
TEL12-125	111.2019.02	19"
TEL12-125	111.2023.02	23"
TEL12-30 & TEL12-45	111.2019.1616	19"
TEL12-30 & TEL12-45	111.2023.1616	23"

NOTE:  
1.) QUANTITY OF HARDWARE MAY VARY.

ISSUE

ISSUE	DESCRIPTION	Issue By Issue Date	App. By App. Date
1	SEE ECN 16443 Original release of documentation.	KEL 08/08/08	MCM 8/25/08
2	SEE ECN 17482	AMG 10/26/10	MCM 11/17/10
3	SEE ECN 17689. REMOVED 111.2019.1821 REFERENCE.	WD 4/27/11	MCM 5/2/11
4	PCO# 44270 Updated logo and text from: "C&D" to: "UNIPOWER".	KEL 03/22/17	D.ESSI 3/23/17

UNLESS OTHERWISE SPECIFIED:  
DIMENSIONS ARE IN INCHES  
TOLERANCES ARE:  
FRACTIONAL ± 1/32  
ANGULAR: ± 1  
ONE PLACE DECIMAL ± 0.04  
TWO PLACE DECIMAL ± 0.02  
THREE PLACE DECIMAL ± 0.010  
HOLES +0.004 / -0.002

	NAME	DATE
DRAWN	K.E. LEWIS	08/08/08
CHECKED	MCM	8/25/08
ENG APPR.	DBW	8/25/08
MFG APPR.		

PROPRIETARY INFORMATION

NOT TO BE COPIED, USED, TRANSMITTED, OR DISCLOSED  
WITHOUT PRIOR WRITTEN PERMISSION FROM UNIPOWER, LLC

WORKMANSHIP:  
PER SPEC ENG032

MATERIAL:

FINISH:



TITLE: **BATTERY TRAY,  
19" & 23" RELAY RACK MNT,  
ASSEMBLY DOCUMENTATION**

SIZE	DOC TYPE / NUMBER	ISSUE
<b>B</b>	PN 111-2025-XX	<b>4</b>

SCALE	SHEET	FILE
N/A	1 OF 2	PN111-2025-XX.SLDDRW

