

AGL9233-R2U MODULE

700 WATT SERVER POWER SUPPLY

FAULT-TOLERANT POWER SYSTEM

11.02 x 4.01 x 3.28" | 280 x 101.8 x 83.4mm

DESCRIPTION

UNIPOWER's **AGL9233-R1U** is a 700 Watt fault-tolerant power system manufactured to support high-end server and communication equipment. The power system consists of two AGL3000 Power Modules which mate into the AGLR2U Chassis / Backplane.

The AGL3000 Power Module:

- Universal AC Input with Active PFC
- >92% Efficiency (at 50% Load)
- +12V Main (with 5VSB & -12V outputs)
- Active Current Share with OR'ng Diodes
- >100,000 Hours MTBF (MIL217F)

The AGLR2U Chassis / Backplane:

- DC-DC Regulation for 5V & 3.3V outputs
- Parallel Connecting the Power Modules
- ATX Output Harness (standard)

The power system provides hot-swap / redundant functionality of the AC-DC Power Supplies and the backplane's dc-dc regulators feature reliability measured in millions of hours to support high-reliability applications.

FEATURES

- ◆ Up to 87% Efficiency
- ◆ 2U High: 3.28"
- ◆ 0°C to +50°C Operation (Full Load)
- ◆ Universal AC Input with Active PFC
- ◆ ATX 2.0 Compliant Output Voltages
- ◆ Hot Swappable / Redundant Operation
- ◆ International Safety Approvals
- ◆ Class B EMI Filter
- ◆ LED Indicators
- ◆ TTL Compatible Status & Control Signals
- ◆ PMBus Serial Communications
- ◆ Variable Speed Cooling Fans

TWO-YEAR WARRANTY

INTERNATIONAL STANDARDS

UL/cUL 60950-1, TUV EN 60950-1
CB IEC 60950-1, WEEE, CE Mark (LVD)



Fault-Tolerant Power System

MODEL	POWER	VOUT	IOUT
AGL9233-R2U (integrated system)	700W	3.3V 5V 12V -12V 5VSB	25A 25A 57A 0.5 3A

Component Parts

MODEL	DESCRIPTION
AGL3000	750 Watt Hot-Swap Power Module
AGLR2U	700 Watt Chassis & Backplane

1. Purpose

This specification defines the performance characteristics and functions of a 750 watts 2U form factor of switch mode redundant power supply with Active PFC (Power Factor Correction) and PMBus

2. AC Input Requirements

2.1 Input Voltage and Frequency

Voltage (sinusoidal) : 100~240 VAC full range, with $\pm 10\%$ tolerance. Input frequency ranges from 47Hz~63Hz

2.2 AC Input Current and Inrush Current

AC line inrush current shall not damage any component nor cause the AC line fuse to blow under any DC conditions and with any specified AC line input voltage and frequency. Repetitive On/Off cycling of the AC input voltage shall not damage the power supply.

Table 1: AC Input Current and Inrush Current

Input Voltage	Maximum Input Current	Maximum Inrush Current	Output Power
100~240VAC	10~4A	35A peak@115VAC 70A peak@240VAC	750W

2.3 Input Power Factor Correction (Active PFC)

The power factor at 100% of rated load shall be ≥ 0.95 at nominal input voltage.

2.4 AC Line Transient Specification

AC line transient conditions are characterized as “sag” and “surge” conditions. Sag conditions (also referred to as “brownout” conditions) will be defined as the AC line voltage dropping below nominal voltage. Surge conditions will be defined as the AC line voltage rising above nominal voltage. The power supply shall meet the regulation requirements under the following AC line sage and surge conditions.

Table 2: AC Line Sag Transient Performance

Duration	Sag	Operating AC Voltage	Line Frequency	Load	Performance Criteria
Continuous	10%	Nominal AC Input ranges	50/60 Hz	100%	No loss of function or performance
0-1 AC cycle	100%	Nominal AC Input ranges	50/60 Hz	60%	No loss of function or performance
> 1 AC cycle	> 10%	Nominal AC Input ranges	50/60 Hz	100%	Loss of function Acceptable,

Table 3: AC Line Surge Transient Performance

Duration	Surge	Operating AC Voltage	Line Frequency	Performance Criteria
Continuous	10%	Nominal AC Voltage	50/60 Hz	No loss of function or performance
0 - ½ AC cycle	30%	Mid-point of Nominal AC Voltage	50/60 Hz	No loss of function or performance

3. DC Output Specification

3.1 Output Power / Currents

Table 4: Load Range

Voltage	Minimum Continuous Load	Maximum Continuous Load
+3.3V	0A	25A
+5V	0A	25A
+12V	0.1A	62A
-12V	0A	0.5A
+5VSB	0A	3A

Notes:

- 1: The +3.3 & +5 Volt total outputs shall not exceed 150W.
- 2: Noise bandwidth is from DC to 20 MHz

3.2 Voltage Regulation, Ripple and Noise

Table 5: Regulation, ripple and noise

Output Voltage	+3.3V	+5V	+12V	-12V	+5VSB
Load Reg.	±5%	±5%	±5%	±5%	±5%
Line Reg.	±1%	±1%	±1%	±1%	±1%
Ripple & Noise	60mV	60mV	120mV	120mV	60mV

Ripple and noise shall be measured using the following methods:

- a) Measurements made differentially to eliminate common-mode noise
- b) Ground lead length of oscilloscope probe shall be ≤ 0.25 inch.
- c) Measurements made where the cable connectors attach to the load.
- d) Outputs bypassed at the point of measurement with a parallel combination of 10uF tantalum capacitor in parallel with 0.1uF ceramic capacitors.
- e) Oscilloscope bandwidth of 0 Hz to 20MHz.
- f) Measurements measured at locations where remote sense wires are connected.
- g) Regulation tolerance shall include temperature change, warm up drift and dynamic load

3.3 Capacitive Loading

The power supply shall be stable and meet all requirements in the following table, except dynamic loading requirements.

Table 6: Capacitive Loading Conditions

Output	MIN	MAX	Units
+3.3V	10	12,000	uF
+5V	10	12,000	uF
+12V	10	11,000	uF
-12V	1	350	uF
+5VSB	1	350	uF

3.4 Dynamic Loading

The output voltages shall remain within the limits specified in *Table-Regulation, ripple and noise* for the step loading and within the limits specified in *Table-Transient Load Requirement* for the capacitive loading. The load transient repetition rate shall be tested between **50Hz and 5kHz** at duty cycle ranging from 10%-90%. The load transient repetition rate is only a test specification. The Δ step load may occur anywhere within the MIN load to the MAX load shown in *Table-Load Range*.

Table 7: Transient Load Requirements

Output	Δ Step Load Size	Load Slew Rate	Capacitive Load
+5V	30% of Max. Load	0.5 A/uS	1000 uF
+3.3V	30% of Max. Load	0.5 A/uS	1000 uF
+12V	50% of Max. Load	0.5 A/uS	2200 uF
+5VSB	25% of Max. Load	0.5 A/uS	1 uF

3.5 Overshoot at Turn-on/Turn-off

Any output overshoot at turn on shall be less than 10% of the nominal output value. Any overshoot shall recover to be within regulation requirements in less than 10ms.

3.6 Timing Requirements

Table 8: Output Voltage Timing

Item	Description	MIN	MAX	Units
Tvout_rise	Output voltage rise time from each main output	1	20	mS
	Output voltage rise time for the 5Vsb out put	1	25	mS
Tvout_on	All main output must be within regulation of each other within this time.		50	mS
Tvout_off	All main output must leave regulation within this time		400	mS

Figure 1: Output Voltage Timing

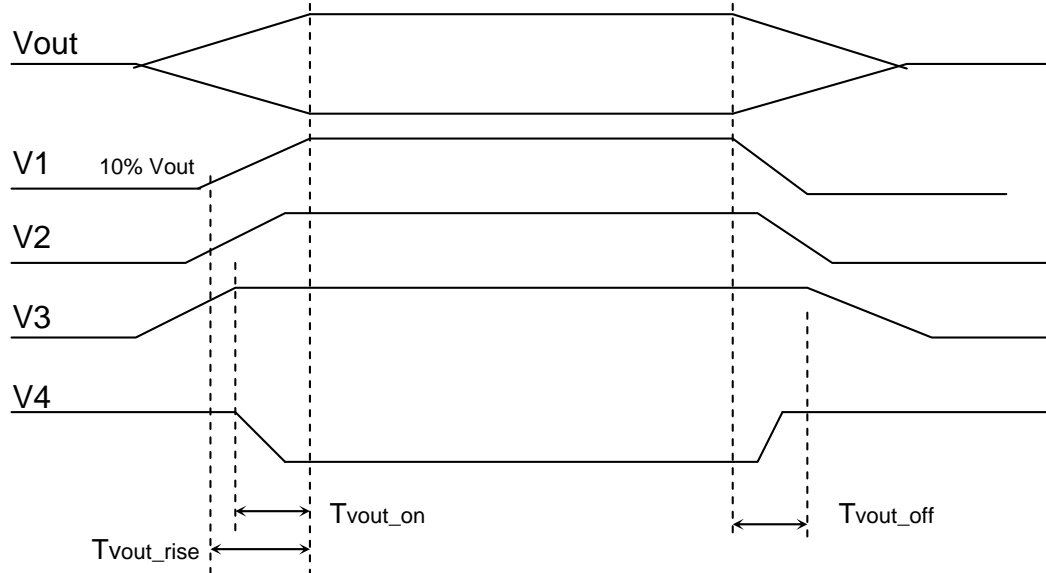
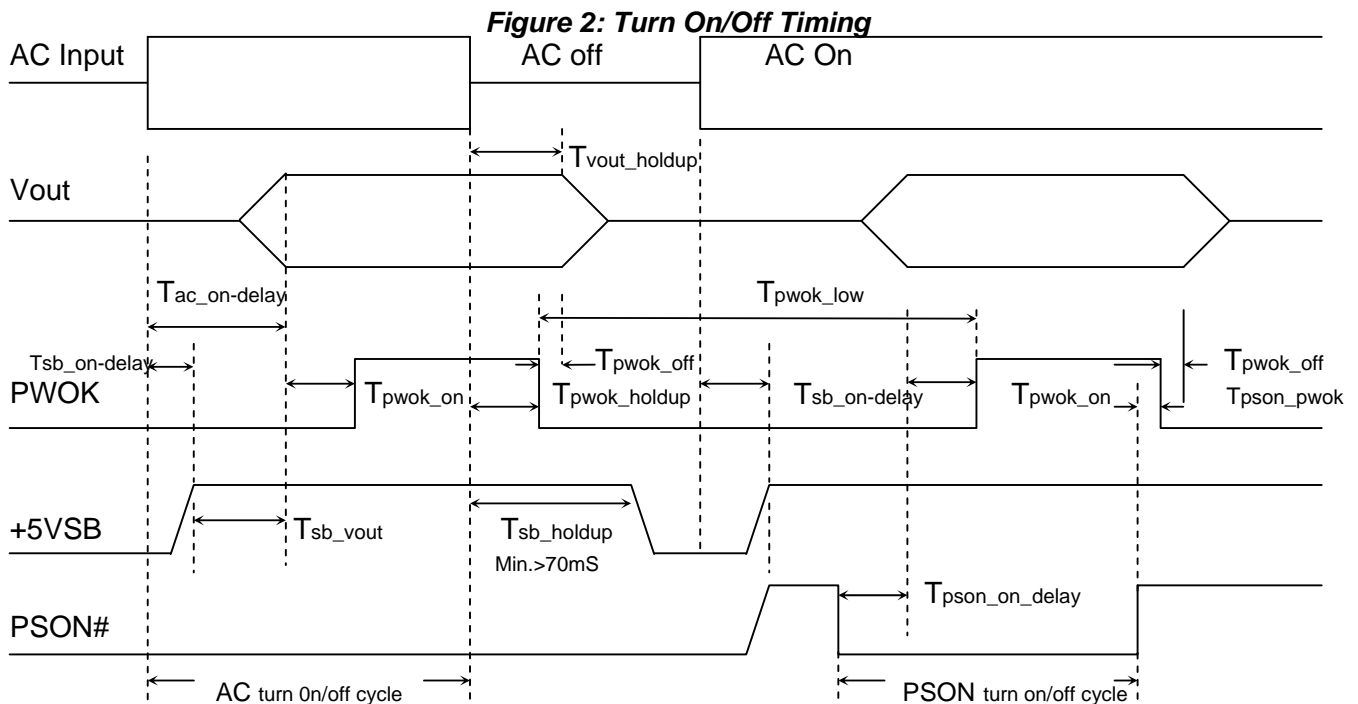

Table 9: Turn On/Off Timing

Item	Description	MIN	MAX	Units
Tsb_on-delay	Delay from AC being applied to +5VSB being within regulation.		1500	mS
Tac_on-delay	Delay from AC being applied to all output voltages being within regulation.		2500	mS
Tvout_holdup	Time all output voltage stay within regulation after loss of AC tested at 60% of maximum load.	17		mS
Tpwok_holdup	Delay from loss of AC deassertion of PWOK tested at 60% of maximum load.	16		mS
Tpson_on_delay	Delay from PSON# active to output voltage within regulation limits.	5	400	mS
Tpson_pwok	Delay from PSON# deactive to PWOK being deasserted.		50	mS
Tpwok_on	Delay from output voltage within regulation limits to PWOK asserted at turn on.	100	1000	mS
Tpwok_off	Delay from PWOK deasserted to output voltages (+5V, +3.3V, +12V, -12V) dropping out of regulation limits. Tested at 60% of maximum load.	1		mS
Tpwok_low	Duration of PWOK being in the deasserted state during an off/on cycle using AC or the PSON# signal. .	100		mS
Tsb_vout	Delay from +5VSB being in regulation to O/Ps being in regulation at AC turn on.	50	1000	mS



3.7 Efficiency

The minimum power module efficiency shall be 92% at 50% of rated load, measured at input voltage 230 V. Fan is powered by external DC source.

4. Protection Circuits

Protection circuits inside the power supply shall cause only the power supply's main outputs to shutdown. If the power supply latches off due to a protection circuit tripping, an AC cycle OFF for 15 sec and a PSON# cycle HIGH for 1 sec must be able to restart the power supply.

4.1 Over Current Protection (OCP)

The power supply shall have current limit to prevent the +5V, +3.3V, and +12V outputs from exceeding the values shown in **Table-Over Current Protection**. The power supply shall latch off if the current exceeds the limit.

Table 10: Over Current Protection

Voltage	Minimum	Maximum	Shutdown Mode
+5V	27A	40A	Latch Off
+3.3V	27A	40A	Latch Off
+12V	68A	100A	Latch Off

4.2 Over Voltage Protection (OVP)

The power supply shall shut down and latch off after an over voltage conditions occurs.

Table 11: Over Voltage Protection

voltage	Minimum	maximum	Description: 端口规格	Shutdown mode
+5V	+5.7V	+6.5V		Latch Off
+3.3V	+3.9V	+4.5V		Latch Off
+12V	+13.3V	+14.5V		Latch Off

4.3 Short Circuit Protection

The power supply shall shut down in latch off mode when the output voltage is short circuit.

4.4 No Load Operation

No damage or hazardous condition should occur with all the DC output connectors disconnected from the load. The power supply may latch into the shutdown state.

4.5 Over Temperature Protection (OTP)

The power supply will shut down when an over temperature condition occurs; no damage shall be caused.

5. Environmental Requirements

5.1 Temperature

Operating Ambient, normal mode (inlet air): 0°C ~ 50°C (32°F~ 113°F)

Non-operating Ambient:: -40°C ~ 70°C (-40°F~ 158°F)

5.2 Humidity

Operating: 20% ~ 90%RH non-condensing

Non-Operating: 5% ~ 95%RH non-condensing

5.3 Altitude

Operating: Sea level to 10,000 ft

Non Operating: Sea level to 40,000 ft

5.4 Mechanical Shock

Non-Operating: 50 G Trapezoidal Wave, 11mS half sin wave. The shock is to be applied in each of the orthogonal axes.

5.5 Vibration (Non-Operating)

The power supply shall be subjected to a vibration test consisting of a 10 to 300 Hz sweep at a constant acceleration of 2.0g for duration of one (1) hour for each of the perpendicular axes X, Y and Z (0.1 octave/minute). The output voltages shall remain within specification.

5.6 Electromagnetic Compatibility

5.6 Electromagnetic Compatibility

Table 12: EMC Requirements

Electromagnetic Interference	FCC CFR Title 47 Part 15 Sub Part B EN55022/EN55024	Conducted B Class Radiated A Class		
Harmonics	IEC61000-3-2 Class D			
Flicker	IEC61000-3-3			
ESD Susceptibility	EN-61000-4-2	±8KV by Air, ±4KV by Contact Performance Criteria B		
Radiated Susceptibility	EN61000-4-3	80MHz~1000MHz (3V/m(mns) Amplitude 80% AM 1KHz Criteria A		
EFT/Burst	EN61000-4-4	5KHz, AC: 1KV, DC: 0,5 KV, Performance Criteria B		
Surge Voltage	EN61000-4-5	Line-to-Line: 1KV Line-to-Ground: 2KV Performance Criteria B		
Conducted Susceptibility	EN61000-4-6	0.15MHz~80MHz 3V/m Amplitude 80% AM 1KHz Performance Criteria A		
RF Conducted	EN61000-4-8	50 Hz/3A(ms)/m Performance Criteria A		
Voltage Dips and Interruptions	EN61000-4-11	30%(Voltage Dips) 60%(Voltage Dips) >95%(Voltage Dips)	10 ms 100ms 500ms	Criteria B Criteria C Criteria C
Leakage Current	EN60950-1	3.5mA@240VAC		

5.7 Safety Agency Requirements

This power supply is designed to meet the following safety

Table 13: Product Safety

Product Safety:	UL,cUL	UL60950-1
	CB	IEC60950-1
	TUV	EN60950-1
	CCC	

6. Reliability

6.1 Mean Time Between Failures (MTBF)

The MTBF of the power supply shall be calculated utilizing the Part-Stress Analysis method of MIL217F. The calculated MTBF of the power module shall be greater than 100,000 hours under the following conditions:

Full rated load; 120V AC input; Ground Benign; 25°C

7. PMBus Command Codes (Standard Version)

Command Summary

Command Code	Command Name	SMBus Transaction Type	Number of Data Bytes
19h	CAPABILITY	Read Byte	1
1Ah	QUERY	Read Byte	1
88h	READ_VIN(Note1)	READ WORD	2
89h	READ_IIN	READ WORD	2
8Bh	READ_VOUT	READ WORD	2
8Ch	READ_IOUT	READ WORD	2
8Dh	READ_TEMPERATURE_1	READ WORD	2
90h	READ_FAN_SPEED_1	READ WORD	2
91h	READ_FAN_SPEED_2	READ WORD	2
96h	READ_POUT	READ WORD	2
97h	READ_PIN	READ WORD	2
98h	PMBUS_REVISION	READ BYTE	1
99h	MFR_ID	R/W Block	Variable
9Ah	MFR_MODEL	R/W Block	Variable
9Bh	MFR_REVISION	R/W Block	Variable
9Eh	MFR_SERIAL	R/W Block	Variable
A0h	MFR_VIN_MIN	READ_WORD	2
A1h	MFR_VIN_MAX	READ_WORD	2
A7h	MFR_POUT_MAX	READ_WORD	2
B0h	USER_DATA_00	READ BYTE	1

Note1: If AC Input= 90V ~ 180V PMBus sent the value of 115V
 If AC Input= 181V ~ 264V PMBus sent the value of 230V

MFR Meaning

Command Code	Command Name	Meaning
99h	MFR_ID	UNIPOWER
9Ah	MFR_MODEL	AGL3000
9Bh	MFR_REVISION	A0 ~ Z9
9Eh	MFR_SERIAL	Code = 12
A0h	MFR_VIN_MIN	100VAC
A1h	MFR_VIN_MAX	240VAC
A7h	MFR_POUT_MAX	750W

Status BYTE Message Contents

Command code = B0h (Command name = USER_DATA_00)

Bit Number	Status Bit Name	Meaning
7	Reserved	Default=0
6	Reserved	Default=0
5	Reserved	Default=0
4	Reserved	Default=0
3	Reserved	Default=0
2	Module Status	Inserted=0, Not inserted=1
1	PS_ON Status	PS_OFF=0, PS_ON=1
0	AC Status	AC OK=0, AC Fail=1

Device address locations

PDB addresss A0/A1	0/0	0/1	1/0	1/1
PSU PMBUS Device	B0h	B2h	B4h	B6h

8. LED Indicators

There will be a LED on each power module to indicate power status

Power Supply Status	Color
Works Normally	Green
Standby (Only +5VSB output)	Blinking Green
Power Fail	Red
Fan Fail	Blinking Red

9. Signals from Wire Harness

Power Supply Status	Signal Type
Works Normally	High
Power Fail	Low
Fan Fail	Low

Alarm reset is used to clear power fail status by shorting circuit activities.

Buzzer shall alarm if signal goes low.

10. Mechanical Overview

Dimension: 101.8mm(W) x 83.4mm(H) x 280mm(D)

Weight: About 4.0 Kg

Standard Cable Assemblies are 500mm ±20mm. Customer specified cable assemblies available upon request and will be designated by customer specific suffix in the final part number.

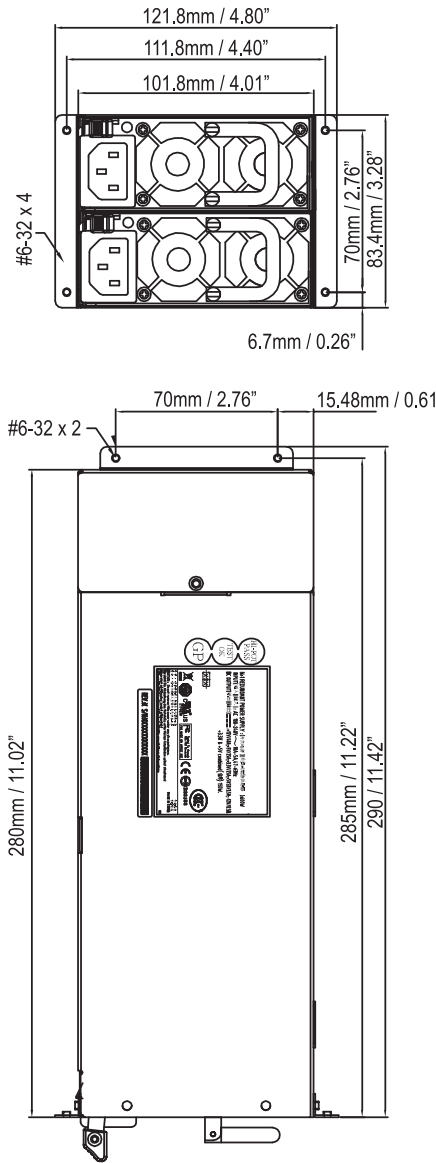

Unit: mm | inches

