

10-320

For utility applications

- 24-, 48- and 130-volt Models
- 6 to 50 Amperes Output
- High Efficiency
- High Power Factor
- Low Noise Levels
- Current Limiting
- Easily Maintained



THREE YEAR WARRANTY

www.unipowerco.com

NORTH AMERICA CALL: +1-954-346-2442 • EUROPE CALL: +44 1903 768200

ARE SERIES FLOAT RECTIFIERS

Controlled ferroresonant float rectifiers have many inherent advantages ... voltage regulation, short circuit protection, low operating costs (a combination of high efficiency and high power factor), easy maintenance and high reliability.

The ARE Series of float rectifiers combines these inherent advantages with advanced rectifier, control and filter circuitry, and user-oriented packaging. Designed specifically for utility and communication applications, the ARE Series rectifiers are easily adjusted to meet your specific operating requirements and will provide years of low-maintenance service.

INPUT

All transformers are dual wound for either 120, 208, 240 volts (-12, +10 percent) or for 208, 240, 480 volts, single phase, 60 Hz \pm 5 percent.

REGULATIONS

DC voltage is maintained within $\pm 1/2$ percent at any load from no load to full load with ± 10 percent variation (or ANSI standard ranges) in the AC input voltage while floating rated number of cells.

Control is accomplished with a single control board with operation on or off a battery.

During operation, the maximum output voltage transient does not exceed 5 percent of the initial steady-state voltage for sudden load changes between 20 percent and 100 percent of rated output. Recovery takes less than 200 milliseconds. Operation off the battery is stable under all conditions of line and load (within stated limits).

Turn-on under all conditions of line and load has a "soft-start" characteristic without overshoot.

REGULATION CURVE

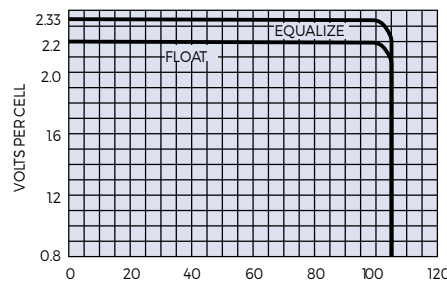

ELECTRICAL NOISE

For 24- and 48-volt models, the filtering provided produces a ripple level of less than 30 millivolts rms with electrical noise less than 22 dB_rn with C message weighing on a type 3A noise measuring set when connected to a battery with an

eight-hour capacity rating of four times the rectifier current rating.

For 130-volt models, the filtering provided produces a ripple level of less than 30 millivolts rms when connected to a battery with an eight-hour capacity rating of four times the rectifier current rating.

The total dynamic response of the control circuitry permits all ARE rectifiers to operate as power supplies (at increased ripple levels) when the batteries are removed for service.

EFFICIENCY AND POWER FACTOR

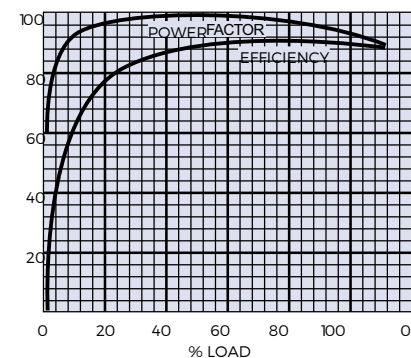

PRINCIPLES OF CONTROLLED FERRORESONANT OPERATION

The conventional ferroresonant transformer has inherently good regulation of output voltage against wide variations of input voltage. Its high reactance provides protection against overload and short circuit of the output. The output voltage does vary with changes in load and frequency. The output winding is on the same leg of the core as the resonant winding, and the resonant capacitor acts to maintain this core section at a high level of saturation, resulting in a constant voltage. To provide a precise constant voltage, it is necessary to control this level of core saturation. This is accomplished in the controlled ferro by shunting the resonant circuit with a switching device in series with an inductor. As shown in the block diagram, the unique ARE circuit senses the start of the resonant capacitor charge cycle and switches the thyristor on to interrupt the cycle. The point of interruption is delayed by a signal fed back from the output to allow the voltage to rise to the preset level. In the event the current exceeds a preset level, the signal from the shunt overrides the voltage regulator to limit current; thus, precise control of voltage and current is maintained. If a fault occurs allowing a higher voltage to develop on the output, a sensing circuit causes the AC input breaker to shut down the charger.

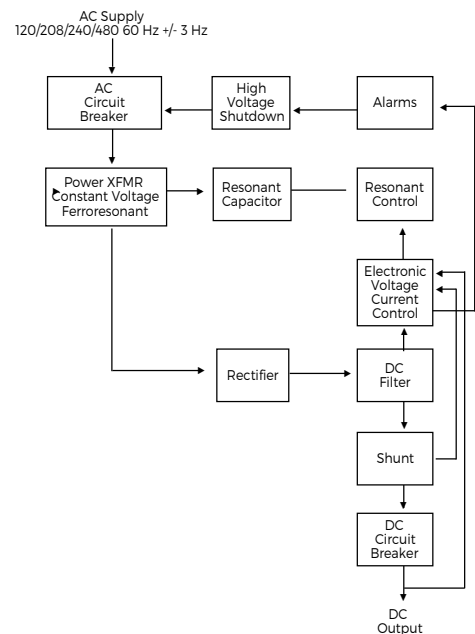

CURRENT LIMITING CIRCUIT

The current limiting circuit is factory set at 110 percent of rated DC output but can be adjusted down to 90 percent and up to 125 percent for intermittent duty up to two hours.

FLOAT AND EQUALIZE VOLTAGES

To accommodate different battery types, both the float and the equalize voltages are continuously adjustable (no taps) over the nominal voltage range (24-volt; 24-30V; 48-volt models; 48-60V; 130-volt models; 120-145V).

24-, 48- and 130-volt models can be equipped with a float voltage compensation circuit, which can be connected up to 10 feet from charger. The temperature compensation circuitry will correct both the float and equalize voltages by 2.0 mV per degree F per cell [added for temperatures below 77F (25C) and subtracted for temperatures above 77F (25C)].

CIRCUIT PROTECTION

A two-pole shunt-trip AC circuit breaker is provided for input protection. A two-pole DC circuit breaker is provided in the output.

An AC power failure alarm relay provides Form C contacts, which operate in the event of an AC failure.

AMBIENT OPERATING TEMPERATURES

All ARE rectifiers will operate at 110 percent of rated DC output, continuously in temperatures from 32F to 122F (0C to 50C). These units can be safely stored for up to one year at temperatures ranging from -40F to 185F (-40C to +85C).

BATTERY ELIMINATOR OPERATION

All ARE rectifiers will operate as a power supply without a battery at the following ripple levels:

- 24- and 48-volt models ("E" suffix) less than 30 millivolts rms
- 130-volt models ("F" suffix) less than 100 millivolts

MECHANICAL FEATURES

- Door opens approximately 180 degrees for easy access to interior
- The control board is mounted on the rear of the door for easy access
- Serviceable components are accessible and removable from the front
- Input and output connections are easily accessible
- Knockouts for cables are provided
- Clear space is provided in floor area for bottom entrance
- Cabinets can be relay rack, wall or floor mounted

STANDARD EQUIPMENT

- High-voltage shutdown
- Flush-mounted, voltmeter and ammeter, 3.5in (89mm) case, two percent accuracy
- Float and equalize potentiometers with equalize switch
- AC power failure alarm relay
- AC on lamp

OPTIONAL EQUIPMENT

- No-charge alarm - load sharing
- High- and low-voltage alarm
- High DC voltage alarm with adjustable time delay
- Ground detection alarm
- 0 to 255-hour equalize timer
- Blocking diode
- Lightning protection device
- 1 percent meters
- Remote temperature probe with temperature compensation circuitry for 48-volt and 130-volt models
- 50 Hz ratings

FLOAT VOLTAGE TEMPERATURE COMPENSATION CIRCUIT

for single-phase, 24-, 48-, and 130-volt are chargers (50 or 60 hertz)

- Extends battery life
- Wide temperature range
- Rugged, shock-resistant design
- Unaffected by severe environmental exposure

The life of your valve-regulated (sealed) and flooded batteries is extended with the temperature compensating circuit from C&D Technologies. Consisting of a probe and a control board, the probe signal and control circuit interact to automatically adjust float voltage.

Encompassing a wide temperature range, the rugged design of the probe is unaffected by severe environmental exposure.

In order to monitor temperature, the probe needs only to be installed near the battery - fastened either on the battery rack or wall, equidistant from the bottom and top of rack. Not limited by long distances, it can be extended in the field up to 100 feet (30 meters).

The compensation circuit can either be ordered with the ARE single-phase, 130-volt chargers (50 or 60 Hertz), or can be retrofitted in the field. Field modification is as simple as replacing the control board and mounting the temperature probe.

TYPICAL CABINET DIMENSIONS

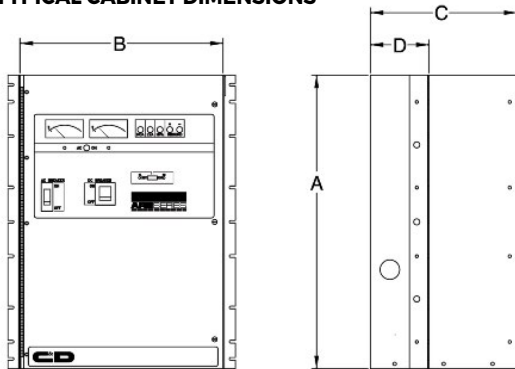

Cabinet	A	B	C	D
12	12.25 in 311 mm	17.00 in 432 mm	14.00 in 356 mm	5.00 in 127 mm
24	24.50 in 622 mm	17.00 in 432 mm	14.00 in 356 mm	5.00 in 127 mm
30	30.00 in 762 mm	20.50 in 521 mm	15.00 in 481 mm	6.00 in 152 mm
36	36.00 in 914 mm	20.50 in 521 mm	18.00 in 457 mm	10.63 in 270 mm

- 17-inch (432 mm) wide cabinets can be used in 19-inch (483 mm), 23-inch (584 mm) or 30-inch (762 mm) relay racks.
- 20.5 inch (521 mm) wide cabinets can be used in 23-inch (584 mm) or 30-inch (762 mm) racks only.
- Rack angles mount at rear for wall mounting.
- Floor brackets are available for all models instead of relay rack mounting angles when ordered with charger.

24-volt output

Model	Input Volts	AC amps	DC amps	Cabinet	Recommended DC cable size AWG	Circuit breaker DC	Approx. ship. wt.	
							lb	kg
ARE24AC6E	120/208/240	2/1.1/1	6	12	14	10	65	30
ARE24AC12E	120/208/240	4/2.3/2	12	12	10	20	72	33

48-volt output

Model	Input volts	AC amps	DC amps	Cabinet	Recommended DC cable size AWG	Circuit breaker DC	Approx. ship. wt.	
							lb	kg
ARE48AC6E	120/208/240	4/2.3/2	6	12	14	10	72	33
ARE48AC12E	120/208/240	7/4/3.5	12	12	10	20	95	43

130-volt output

Model	Input volts	AC amps	DC amps	Cabinet	Recommended DC cable size AWG	Circuit breaker dc	Approx. ship. wt.	
							lb	kg
ARE130AC6F	120/208/240	8.5/5/4	6	12	14	10	100	46
ARE130AC12F	120/208/240	18/10/9	12	24	10	20	170	77
ARE130AC16F	120/208/240	22/13/11	16	24	10	20	185	84
ARE130AC25F	120/208/240	35/20/17	25	30	8	40	325	148
ARE130AC35F	120/208/240	50/29/25	35	36	8	50	460	209
ARE130CE25F	208/240/480	20/17/8.5	25	30	8	40	325	148
ARE130CE35F	208/240/480	29/25/12.5	35	36	8	50	460	209
ARE130CE50F	208/240/480	40/35/17.5	50	36	4	70	600	273