



**OPERATING MANUAL
POWER DISTRIBUTION PANELS
DPB1U & DPG1U SERIES**

www.unipowerco.com

Manual No. DPB-DPG-4

dpb_dpg-man-rev4-0317.indd

© 2017 UNIPOWER LLC

All Rights Reserved

Contents

| | | |
|------|-----------------------------------|----|
| 1.0 | INTRODUCTION | 4 |
| 2.0 | FEATURES & OPTIONS..... | 5 |
| 3.0 | PRODUCT LINE..... | 5 |
| 4.0 | SAFETY & INDUSTRY STANDARDS | 6 |
| 5.0 | WARRANTY (summary) | 6 |
| 6.0 | DESCRIPTION OF OPERATION | 7 |
| 7.0 | SPECIFICATIONS | 8 |
| 8.0 | FRONT PANEL DESCRIPTION | 8 |
| 9.0 | BACK PANEL DESCRIPTION | 10 |
| 10.0 | UNPACKING AND INSPECTION..... | 13 |
| 11.0 | INSTALLATION | 14 |
| 12.0 | SETUP AND TESTING | 16 |

FIGURES

| | |
|---|----|
| Figure 1. DPG1U & DPU1U Front Views | 4 |
| Figure 2. Block Diagram | 7 |
| Figure 3. DPB1U Front Panel View | 8 |
| Figure 4. DPG1U Front Panel View | 8 |
| Figure 5. Back Panel View | 10 |
| Figure 6. Input Bus Bar Detail | 10 |
| Figure 7. Output Barrier Strip Detail..... | 11 |
| Figure 8. Alarm Contact & Ground Detail..... | 12 |
| Figure 9. Series Connection of Multiple Panels..... | 14 |

TABLES

| | |
|--|----|
| Table 1. Basic Configurations | 5 |
| Table 2. LED State Definitions | 7 |
| Table 3. GMT Fuse Values..... | 9 |
| Table 4. Input Cable Lug Sizes & Types | 11 |
| Table 5. Alarm Relay Contacts | 12 |
| Table 6. Relay State Definitions | 12 |

OPERATING MANUAL

DPB1U & DPG1U SERIES

DC POWER DISTRIBUTION PANELS

1.0 INTRODUCTION

These distribution panels provide protected power distribution to telecommunication equipment. They offer fuse or circuit breaker positions on the A and B sides of the panel. The A and B loads of the distribution panel are totally independent and isolated from each other. There is a green/red LED for each load to indicate normal operation or an open circuit due to a blown fuse or tripped circuit breaker.

The panels are only 1.75 inches (1 mounting position) high to minimize rack space and can be mounted in either a 19- or 23-inch relay rack with corresponding brackets. They can be mounted from the front of the rack with offsets every 1/4-inch from front to back to align with existing rackmounted equipment.

Figure 1 shows the two series of panels. The first is the DPG1U Series which has 10 GMT fused circuits on both A and B sides. The second is the DPB1U Series with up to 6 circuit breaker circuits on both A and B sides.



DPG1U: GMT Fuse Distribution Panel



DPB1U: Circuit Breaker Distribution Panel

Figure 1. DPG1U & DPG1U Front Views

The panels can be configured for 12, 24 or 48 volts and are polarity neutral. Because the A and B sides are independent and isolated, they can be configured separately. For example, the A side can be 48V and the B side can be 24V. The voltage and of each side must be configured at the factory..

Each bus (A and B) has a green/red visual alarm and one Form C relay alarm contact for connection to external audible or visual alarms.

2.0 FEATURES & OPTIONS

2.1 The following is a summary of the important features of the Series.

- ◆ Thin Height: 1.75 inches (1RU)
- ◆ 19 or 23-Inch Rack Mounting
- ◆ Dual A/B Loads
- ◆ Current Capacity: 80 to 150A per Load (Depends on Model)
- ◆ Operating Voltage: 12, 24 or 48VDC
- ◆ POLARITY NEUTRAL
- ◆ Red/Green LED Indicators
- ◆ 1 Form C Relay Contacts per bus
- ◆ Protection: GMT Fuses or Magnetic Circuit Breakers
- ◆ Independent and Isolated Loads
- ◆ Input Connections: Crimp Type Lugs
- ◆ Output Connections: Barrier Terminal Strips

2.2 Options. There are two standard options available:

Option S - This option internally links the A bus to the B bus so that a fully configured unit can be supplied DC from a single feed. The A and B sides must have the same voltage and polarity. Not available with option F.

Option F (special order only) - Fail safe operation for 24 and 48V units. A and B sides with separate feeds operate redundantly so that one feed takes over both sides in case of failure of the other feed. Voltage and polarity of both sides must be the same. Note that this option requires an extended depth chassis. Not available with option S.

3.0 PRODUCT LINE

The following table shows the basic configuration that are available for each type of panel. ‘x’ denotes the voltage and polarity. Full configuration details are given in section 8.

| INPUT FEEDS | MAX. # BREAKERS / FUSES | AMPS EACH FEED | TOTAL AMPS | BASE MODEL |
|-------------|-------------------------|----------------|------------|---------------|
| 1 | 6 Breakers | 150 | 150 | DPB1U-Ax |
| | 12 Breakers | 150 | 150 | DPB1U-Ax-Bx-S |
| 2 | 6 Breakers Each Bus | 150 | 300 | DPB1U-Ax-Bx |
| 1 | 10 Fuses | 80 | 80 | DPG1U-Ax |
| | 20 Fuses | 80 | 80 | DPG1U-Ax-Bx-S |
| 2 | 10 Fuses Each Bus | 80 | 160 | DPG1U-Ax-Bx |

Table 1. Basic Configurations

4.0 SAFETY & INDUSTRY STANDARDS

4.1 DPB1U & DPG1U Series power distribution panels meet the following safety requirements:

STANDARD

UL60950-1, 2nd Edition

CSA22.2 No. 60950-1, 2nd Edition

EN60950-1, 2nd Edition

4.2 DPB1U & DPG1U Series power distribution panels are CE marked to indicate conformance to the European Union's Low Voltage, EMC and RoHS Directives.

4.3 Inadvertent short circuiting of the system battery and/or rectifier by mis-connection or other error could be harmful. This product should be handled, tested and installed only by qualified technical persons who are trained in the use of power systems and are well aware of the hazards involved.

4.4 When operating this Distribution Panels the chassis ground terminal must be connected to the system frame ground or other proper safety ground for the protection of personnel.

4.5 All connections to the Distribution Panels should be carefully checked for errors before applying power to them.

4.6 The internal circuits may present an energy hazardous. The top cover should not be removed. There are no user-serviceable components in these units. Removing the top cover will void the warranty.

5.0 WARRANTY (summary)

DPB1U & DPG1U Series power distribution panels are warranted for two (2) years from date of shipment against defects in material and workmanship. This warranty does not extend to products which have been opened, altered or repaired by persons other than persons authorized by the manufacturer or to products which become defective due to acts of God, negligence or the failure of customer to fully follow instructions with respect to installation, application or maintenance.

For a complete text of UNIPOWER's warranty conditions please request a copy from your local Sales Office.

6.0 DESCRIPTION OF OPERATION

6.1 Power Distribution Circuits. A simplified schematic diagram of the distribution panels is shown in Figure 2. The battery input to each load connects to a high-current copper bus bar from which the individual fuses or circuit breakers distribute power to the loads. The return input connects to a similar bus bar to which the individual loads terminate. The A and B loads are totally independent and isolated with the exception of models incorporating the ‘S’ option.

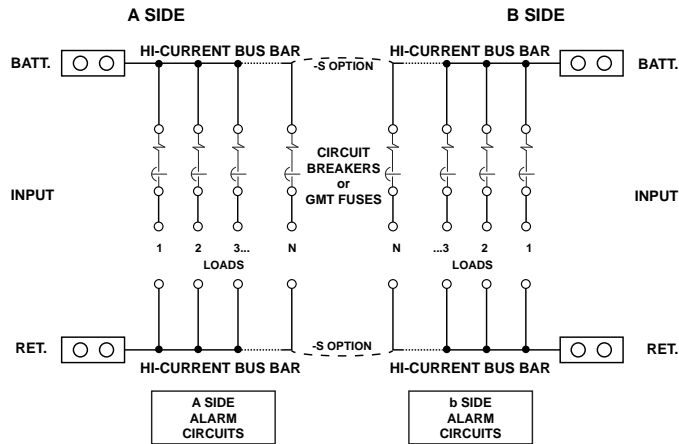

Figure 2. Block Diagram

6.2 Alarm Circuits. The alarm circuits detect a tripped circuit breaker or blown and, in this event, turn on the red part of the LEDs. The alarm circuits also each drive Form C relay contacts. If one or more circuits open or if there is an input power failure, the relays are de-energized and the contacts are used to control external audible or visual alarms. The A and B alarm circuits are also independent and isolated from each other.

LED STATE MEANINGS

| LED State | Meaning |
|-----------|---|
| Green | OK |
| Red | Breaker Trip or Breaker OFF or Fuse Blown |
| OFF | No Input Power |

Table 2. LED State Definitions

7.0 SPECIFICATIONS

The following specifications are typical at 25°C unless otherwise noted.

INPUT / OUTPUT

| | |
|--|---|
| Panel Capacity | See Panel Configuration Table Configuration |
| DPB1U | |
| Single Bus | 1 to 12 Breakers |
| Dual Bus | 1 to 6 Breakers Each |
| DPG1U | |
| Single Bus | 1 to 20 GMT Fuses |
| Dual Bus | 1 to 10 GMT Fuses Each |
| Breaker/Fuse Capacity ¹ | ½A to 50A |
| Voltage ² | |
| 48V Nominal | 42-60VDC |
| 24V Nominal | 21-30VDC |
| 12V Nominal | 10.5-15VDC |
| Polarity | POLARITY NEUTRAL |

ALARMS

| | |
|-----------------------------|---|
| Alarm Indicator | Dual-Color LED Per Bus |
| LED Status Indication | Green = Normal Red = Alarm Off = No Power |
| Alarm Connections | One Form C Relay Contact Per Bus |

SAFETY STANDARDS

UL1950, UL60950-1
CAS22.2 No.950-1, EN60950-1

ENVIRONMENTAL

| | |
|-----------------------------|---------------------------|
| Operating Temp. Range | -10°C to +70°C |
| Storage Temp. Range | -40°C to + 85°C |
| Humidity | 0% to 95%, Non-Condensing |

PHYSICAL SPECIFICATIONS

| | |
|---|---|
| Case Material | Steel |
| Finish | Powder Coat Black |
| Dimensions ³ , Inches (mm) | 1.75 H x 19.00 W x 9.00 D (44.5 x 483 x 229) |
| Weight | 10.30 lbs. (4.67 kg.) |
| Rack Mounting Width | 19 or 23 Inches |

CONNECTIONS

| | |
|---------------------------------|------------------------------------|
| Input Connections | Crimp Type Lug or ¼ - 20 Stud |
| Output Connections | |
| 1-30A | Barrier Terminal Strips, No. 6-32 |
| 40A-50A | Barrier Terminal Strips, No. 10-32 |
| Chassis Ground Connection | No. 8-32 Stud |
| Fail Alarm Connections | .045" sq. Wirewrap Pins |

- NOTES:** 1. See tables for available breaker & fuse sizes.
2. See Ordering Guide to specify voltage.
3. For units with fail safe option the case depth is 10.44 inches (265mm).

8.0 FRONT PANEL DESCRIPTION

The front panel of the DPB1U, shown in Figure 3 below, consists of the A and B sides and a center section. The A and B sides can each accommodate up to 6 hydraulic magnetic circuit breakers rated from 1A to 50A.

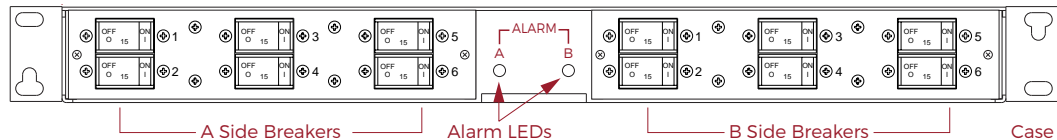

Figure 3. DPB1U Front Panel View

The front panel of the DPG1U, shown in Figure 4 below, consists of the A and B sides and a center section. The A and B sides can each accommodate up to 10 GMT Fuses rated from ½A to 12A.

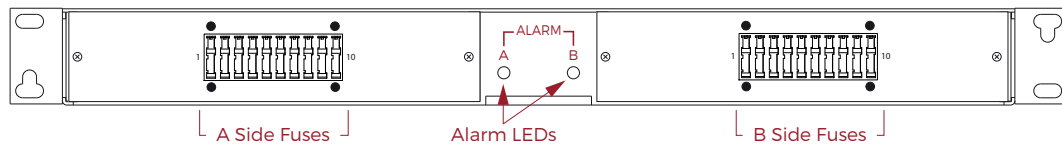
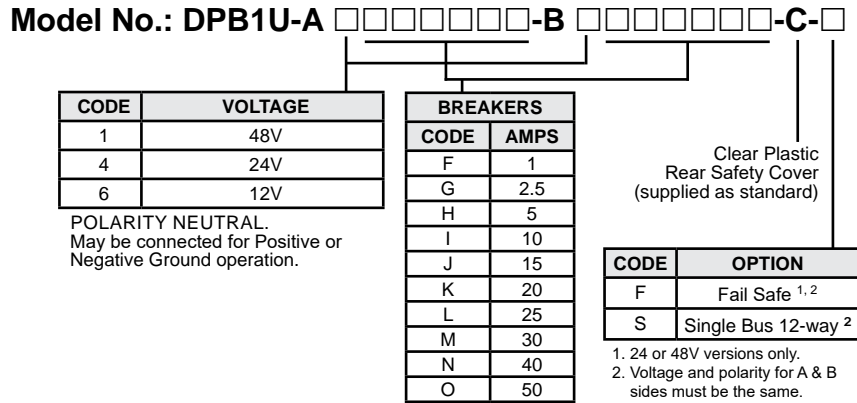

Figure 4. DPG1U Front Panel View

In both cases the center section has two green/red LEDs, one for the A side (left) and the other for the B side (right). At the bottom of this center section is a slot for a wallet and designator card. This card permits the recording of each output circuit by number.

8.1 DPB1U Configuration Details



- Notes:**
1. If section B is not used a blank panel is installed at the factory and the “-B” in the model number is not required.
 2. The sum of all fuse currents on either side must not exceed 150 Amperes.
 3. When the ‘S’ option is specified each side of the panel is limited to 75A.
 4. Failsafe (option F) is to special order only and uses a chassis 10.44” depth. Call sales to discuss your requirements.

8.2 DPG1U Configuration Details

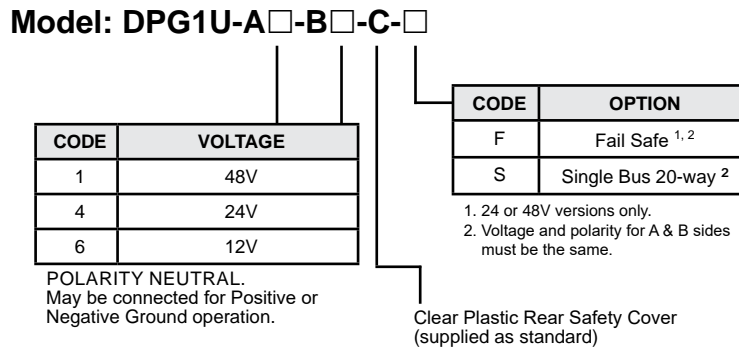

- Notes:**
1. If section B is not used a blank panel is installed at the factory and the “-B” in the model number is not required.
 2. The sum of all fuse currents on either side must not exceed 80 Amperes.
 3. When the ‘S’ option is specified each side of the panel is limited to 75A.
 4. Failsafe (option F) is to special order only and uses a chassis 10.44” depth. Call sales to discuss your requirements.

GMT FUSES (ORDER SEPARATELY)

| AMPS | PART NUMBER | COLOR | AMPS | PART NUMBER | COLOR |
|------|---------------|--------|-------|---------------|--------------|
| ½ | 401-1500-0010 | Red | 3 | 401-1500-0060 | Blue |
| ¾ | 401-1500-0020 | Brown | 5 | 401-1500-0070 | Green |
| 1 | 401-1500-0030 | Gray | 10 | 401-1500-0080 | Red/White |
| 1½ | 401-1500-0040 | White | 12 | 401-1500-0090 | Green/Yellow |
| 2 | 401-1500-0050 | Orange | DUMMY | 401-1500-0100 | |

Table 3. GMT Fuse Values

UNIPOWER recommends Bussman fuses which can be ordered using the part numbers shown.

9.0 BACK PANEL DESCRIPTION

9.1 Back View. Figure 5 shows the back of the DPB1U and DPG1U distribution panel. Inputs are at the left and right ends of the back panel. Side B outputs are at two rows of barrier terminal strips on the left side, and side A outputs are the same on the right side. At the center of the back panel are two spring clamp terminal blocks for the Form C relay contact outputs.

Below these is a chassis ground terminal.

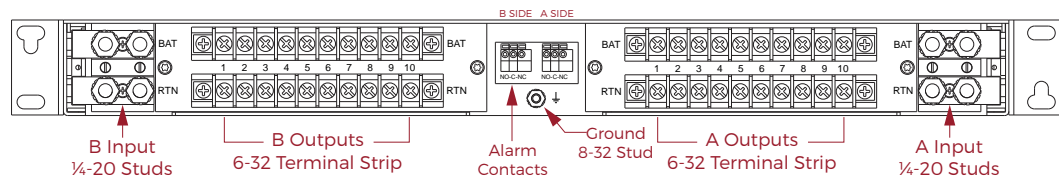

Figure 5. Back Panel View

9.2 Input Connections. See Figure 6. The DC power inputs to the distribution panels are made by means of crimp type lugs or direct connection to 1/4-20 studs to two copper bus bars on side A and side B. The upper bus bar is the battery connection (whether + or -) and the lower bus bar is the return (whether + or -).

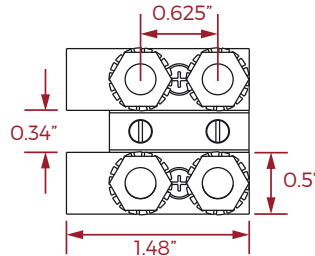

Figure 6. Input Bus Bar Detail

9.3 Crimp Type Lugs. A list of compatible crimp type lugs is shown in the following table for AWG wire sizes from no. 1 to 8 and one- or two- hole lugs. These lugs can be ordered directly from the manufacturer, Panduit Corp., using the model numbers shown in table 4.

A standard kit of four two-hole crimp type lugs for no. 6 AWG copper wire is available from UNIPOWER. Order kit no. 775-1434-0000.

| WIRE AWG | .25DIA. HOLES | PANDUIT CORP. PART NUMBER | UNIPOWER PART NUMBER |
|----------|---------------|---------------------------|--------------------------------|
| 8 | 1 2 | LCA8-14-L LCD8-14A-L | 625-1665-0010 625-1665-0110 |
| 6 | 1 2 | LCA6-14-L LCD6-14A-L | 625-1665-0020 625-1665-0120 |
| 4 | 1 2 | LCA4-14-L LCD4-14A-L | 625-1665-0030 625-1665-0130 |
| 2 | 1 2 | LCA2-14-Q LCD2-14A-Q | 625-1665-0040 625-1665-0140 |
| 1 | 1 2 | LCA1-14-E LCD1-14A-E | 625-1665-0050 625-1665-0150 |

Table 4. Input Cable Lug Sizes & Types

9.4 Output Connections. Output connections for A and B loads are shown in Figure 5. There are 10 sets of barrier terminal strip connections for each side, A and B. The connections are numbered to correspond with the numbers of the front panel breakers. The upper strip connections are from the battery through the breakers; the lower strip connections are the returns. Side B is on the left and side A on the right, as shown.

Each terminal is a no. 6-32 screw and is rated at 30 amperes. Wire sizes from no. 10 AWG up to no. 22 AWG may be used for connections. Figure 7 below shows detailed spacing of the terminals.

When DPB1U is fitted with either 40A or 50A breakers the additional load rating is accommodated by fitting adaptors that bridge two barrier strip terminals and provide a single #10-32 screw. Minimum wire size for these connections is 8 AWG.

A maximum of two high current breakers is allowed on each bus.

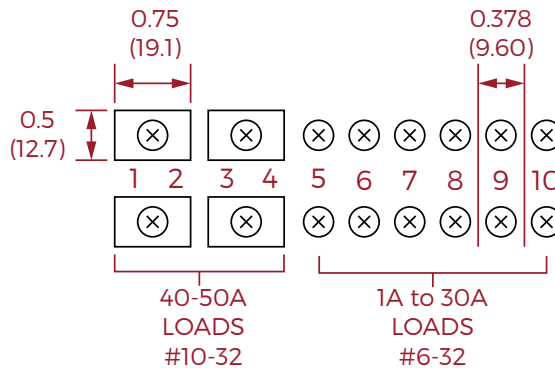

Figure 7. Output Barrier Strip Detail

9.5 Form C Relay Contact Outputs. The center of the back panel has connections to the Form C relay contact outputs for connection to external audible or visual alarm circuits. See Figure 8.

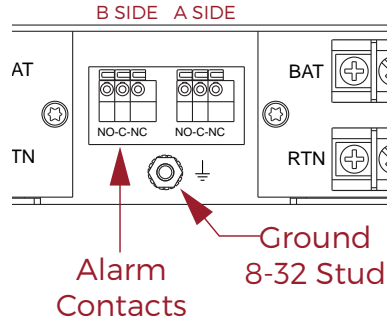

Figure 8. Alarm Contact & Ground Detail

Connection is made via two Phoenix Contact spring clamp terminal blocks. “B SIDE” is for the Form C relay contact of side B and “A SIDE” is for the Form C relay contact of side A. The terminals, viewed from left to right, are the normally open (NO) common (C) and normally closed (NC) contacts, respectively. See table 5 below.

| PIN | FUNCTION | CONTACT SCHEMATIC |
|-----|------------------------|-------------------|
| NC | N.C. (normally closed) | |
| C | C (common) | |
| NO | N.O. (normally open) | |

Table 5. Alarm Relay Contacts

“Normally Closed” and “Normally Open” are defined with the distribution panel powered and providing power to all outputs, i.e. no circuit breakers tripped AND when the input power is connected to a side (A or B), the Form C relay of that side is energized. If there is either loss of input power, one or more circuit breakers trip or the relay is de-energized, the normally open contacts close and the normally closed contacts open. See table 6.

RELAY STATE MEANINGS

| Relay State | Meaning |
|-----------------------------|---|
| Energized (N.C. is closed) | OK |
| De-energized (N.C. is open) | Breaker Trip or Breaker OFF or Fuse Blown |
| | No Input Power |

Table 6. Relay State Definitions

The ratings of the relay contacts are 0.6A at 125VAC or 2A at 30VDC. The spring clamp terminals accept wire sizes nos. 16 to 26 AWG.

- 9.6 Chassis Ground Connection.** Just below the Form C relay contact terminals is the chassis ground terminal. This terminal is a no. 8-32 stud with a nut.

NOTE THAT IT IS ESSENTIAL THAT THIS TERMINAL IS CONNECTED TO THE SYSTEM FRAME GROUND TO ENSURE SAFE OPERATION.

10.0 UNPACKING AND INSPECTION

- 10.1** This power distribution panel was carefully tested, inspected and packaged for shipment from our factory. The unit and circuit breakers are shipped separately. Upon receipt of the unit it should be carefully unpacked and inspected for any damage in shipment.
- 10.2** If there is evidence of damage, do not attempt to test the unit. The freight carrier should be notified immediately and a claim for the cost of the rectifier system should be filed with the carrier for direct reimbursement. Be sure to include the model and serial number of the damaged unit in all correspondence with the freight carrier. Also save the shipping carton and packing material as evidence of damage for the freight carrier's inspection.
- 10.3** UNIPOWER will cooperate fully in case of any shipping damage investigation.
- 10.4** Always save the packing materials for later use in shipping the unit. Never ship the rectifier system without proper packing.

11.0 INSTALLATION

11.1 Mounting. This distribution panel can be mounted in either 19- or 23-inch racks by using the supplied reversible brackets. Mount it from the front of the rack using the correct offsets to align with existing rack-mounted equipment.

The bracket offsets are every quarter inch from front to back.

11.2 Power Connections. Input connections should be made with one- or two-terminal crimp type lugs using copper wire size from no. 1 to 8 AWG, depending on current and wire loop distance. See Sections 9.2 and 9.3. Output connections are made to the barrier terminal strips. See Section 9.4 and Figure 7.

11.2.1 Single feed models with option S - Although these models have both left and right side input bus bars fitted, it is only necessary to connect the input feed to one side for correct operation. As the unused side is directly connected to the live input feed it can be used for supplying additional panels in series. See figure 9 below.

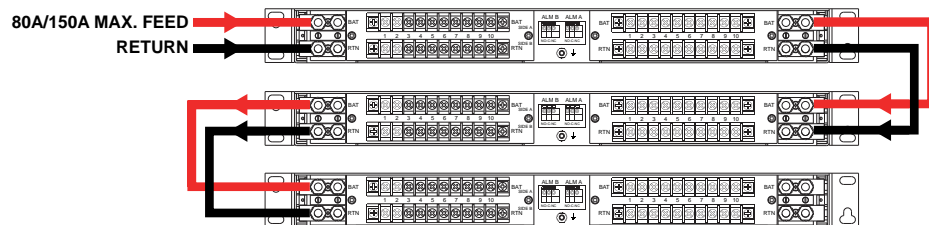

Figure 9. Series Connection of Multiple Panels

When deploying panels with option S, either individually or in a chain, the following must be adhered to so as to meet with UL safety requirements:

- The maximum load drawn through the breaker/fuse outputs either side of the panel may not exceed 75A.
- The current drawn from one panel in the chain to the next is limited to 75A less the total amount being drawn through the breaker/fuse outputs on all previous panels in the chain.

CAUTION: BOTH PAIRS OF INPUT BUS BARS ARE CONNECTED INTERNALLY AND MAY PRESENT AN ENERGY HAZARD. THE SAFETY COVER MUST BE FITTED WHEN INSTALLATION HAS BEEN COMPLETED TO MINIMIZE RISK.

11.3 Alarm Connections. Form C relay contact output connections are made to the spring clamp terminal blocks. See Section 9.5. The chassis ground connection is made to the no. 8-32 stud. See Section 9.6. This safety ground connection should be made before operating the panel.

- 11.4 Checking Connections.** Carefully check the polarity of input connections to the distribution panel and output connections to the load before operating the panel. Reverse connections will not harm the distribution panel as it is POLARITY NEUTRAL. However it may cause serious harm to the load. Check to make sure that the chassis safety ground connection is made. Make sure that all connections are clean and secure to minimize contact resistance.
- 11.5 Rear Safety Cover.** Once all of the above have been completed, fit the clear plastic safety cover to the back of the unit using the supplied mounting studs and screws. Instruction for fitting the mounting studs the panel are included in the accessory kit.

12.0 SETUP AND TESTING

- 12.1** It is not necessary to have the distribution panel mounted in a rack for initial testing. This can be done on a bench. It is also not necessary to have loads connected to the panel for this testing.
- 12.2** With the input power source off, connect the input wires to the A side of the distribution panel. Connect ground to the chassis ground terminal. Insert all fuses into fuse holders or set all circuit breakers to on.
- 12.3** Turn on the input power source. The A side LED should be green. If it is red, one of the fuses is blown or a circuit breaker is tripped. If the LED is off, there is no input power to the unit. Check the output voltage at each set of output terminals with a digital voltmeter.
- 12.4** With the A side LED green, use an ohmmeter to check the Form C relay contact outputs. On J4 measure the resistance between pins 1 and 2. This should read “open”. Measure the resistance between pins 2 and 3. This should read “short”.
- 12.5** On the A side insert a blown fuse into fuse no. 1 position or trip circuit breaker no. 1. The A side LED should turn red. On the upper row (side A) of wire wrap terminals, measure the resistance between pins 1 and 2 and between pins 4 and 5. Both should read “open”. Measure the resistance between pins 2 and 3 and between pins 5 and 6. Both should read “short”. Replace the blown fuse with a good one or reset the circuit breaker.
- 12.6** On the A side check each succeeding fuse by replacing it with a blown fuse, or breaker by tripping it, and verify that the LED turns red. It is not necessary to recheck the Form C relay contacts.
- 12.7** Repeat the same tests of Sections 12.2 through 12.6 on the B side of the distribution panel. Refer to table 5.
- 12.8** The distribution panel may now be connected to its intended application.
- 12.9** If the distribution panel did not operate properly in the above tests, go back and double check the connections and the polarity of the input source to make sure it is correct.

Please note that there are no user serviceable parts inside and that opening the unit will void the warranty.

If you are unable to resolve any problem call your nearest UNIPOWER sales office for support:

US +1 954 346 2442 UK +44 (0)1903 768200

This document is believed to be correct at time of publication and UNIPOWER LLC accepts no responsibility for consequences from printing errors or inaccuracies. Specifications are subject to change without notice.