



OPERATING MANUAL
LOW-VOLTAGE DISCONNECT PANELS
LVD400 & LVD600 SERIES

www.unipowerco.com

Manual No. LVD-201-3
lvd400-600-man-rev3-0315.indd

© 2015 UNIPOWER LLC
All Rights Reserved

CONTENTS

<u>SECTION</u>	<u>TOPIC</u>	<u>PAGE</u>
1.0	Introduction	4
2.0	Features and Options	5
3.0	Product Designation	5
4.0	Safety Warnings	6
5.0	Warranty	6
6.0	Unpacking and Inspection	7
7.0	Specifications	8
8.0	Safety and Industry Standards	9
9.0	Description of Operation	9
10.0	Front Panel Description	10
11.0	Back Panel Power Connections	10
12.0	Form C Relay Contacts	12
13.0	Installation	13
14.0	Setup and Testing	14

ILLUSTRATIONS

<u>FIGURE</u>	<u>TITLE</u>	<u>PAGE</u>
1	LVD400/600 Low-Voltage Disconnect Panel	4
2	Simplified Diagram of LVD400/600	9
3	Back and Side Views of LVD400/600	10
4	Connections for LVD400/600	11
5	Rear Connections to the LVD400/600	12

OPERATING MANUAL LOW-VOLTAGE DISCONNECT PANELS LVD400 & LVD600 SERIES

1.0 INTRODUCTION

- 1.1** This Operating Manual should be read through carefully before installing and operating the LVD400/600 Series Low-Voltage Disconnect Panels.
- 1.2** The LVD400/600 panel provides a disconnect from either the battery or load when the battery voltage drops to a critically low level. The connection for either battery or load disconnect is done by the user. Each LVD400/600 has separate A and B side disconnect panels. The two sides are completely isolated and can be separately configured for 24 or 48 volts. Positive or negative ground can be used. Each side has a set of Form C Relay contacts for alarm purposes.
- 1.3** Figure 1 shows the LVD400/600 Low-Voltage Disconnect Panel. The unit is only two mounting positions high, 3.5 inches, to minimize rack space. It can be specified for either a 19- or 23-inch relay rack mounting.

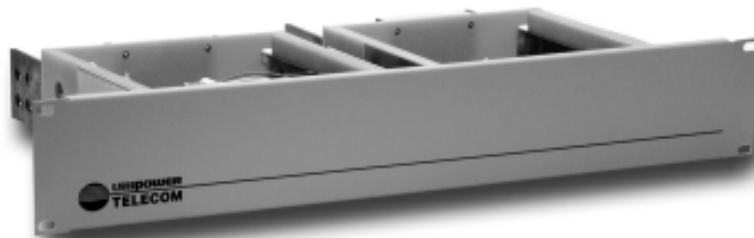

Figure 1. LVD400/600 Low-Voltage Disconnect Panel

2.0 FEATURES AND OPTIONS

2.1 Features. The following summarizes the standard features for the LVD400/600:

- ◆ Two Mounting Positions High: 3.5"
- ◆ 19- or 23-inch Rack Mounting
- ◆ Single or Dual (A/B) LVDs
- ◆ Current Capacity: 400A or 600A per Load
- ◆ Operating Voltage: 24 or 48VDC
- ◆ Positive or Negative Ground
- ◆ Form C Relay Contacts
- ◆ LVD in Series with Battery or Load
- ◆ Field Settable Disconnect & Reconnect Voltages

3.0 PRODUCT DESIGNATION

LV DISCONNECT PANELS

MODEL	CONFIGURATIONS
LVD400-A	SINGLE 400A
LVD400-A-B	DUAL 400A
LVD600-A	SINGLE 600A
LVD600-A-B	DUAL 600A

Model No.: LVD400 -A □ -B □ -□
LVD600

CODE	VOLTAGE
1	48V
3	24V

CODE	PANEL SIZE
19	19" Mounting
23	23" Mounting

Note: For a single unit the A side is specified and used.

4.0 SAFETY WARNINGS

- 4.1 This low-voltage disconnect operates at voltages that could potentially be hazardous. Furthermore, inadvertent short circuiting of the system battery and/or rectifier by misconnection or other error could be harmful. This product should be handled, tested and installed only by qualified technical persons who are trained in the use of power systems and are well aware of the hazards involved.
- 4.2 When operating this LVD400/600 the chassis ground terminal must be connected to the system frame ground or other proper safety ground for the protection of personnel.
- 4.3 All connections to the LVD400/600 should be carefully checked for errors before applying power to it.
- 4.4 This equipment is intended only for installation in a “RESTRICTED ACCESS LOCATION”.

5.0 WARRANTY

LVD400 and LVD600 Series are warranted for two (2) years from date of shipment against defects in material and workmanship. This warranty does not extend to products which have been opened, altered or repaired by persons other than persons authorized by the manufacturer or to products which become defective due to acts of God, negligence or the failure of customer to fully follow instructions with respect to installation, application or maintenance. This warranty is extended directly by the manufacturer to the buyer and is the sole warranty applicable. EXCEPT FOR THE FOREGOING EXPRESS WARRANTY, THE MANUFACTURER MAKES NO WARRANTY, EXPRESS OR IMPLIED, INCLUDING, BUT NOT LIMITED TO, THE WARRANTY OF MERCHANTABILITY OR FITNESS FOR A PARTICULAR PURPOSE. As the sole and exclusive remedy under this warranty, the manufacturer, at its option, may repair or replace the non-conforming product or issue credit, provided the manufacturer's inspection establishes the existence of a defect. To exercise this remedy, the buyer must contact the manufacturer's Customer Service Department to obtain a Return Material Authorization number and shipping instructions. Products returned without prior authorization will be returned to buyer. All products returned for repair must be shipped freight prepaid to UNIPOWER. If the buyer fails to fully comply with the foregoing, the buyer agrees that no other remedy (including, but not limited to, incidental or consequential damages for lost profits, lost sales, injury to person or property or any other incidental or consequential losses) shall be available to the buyer.

6.0 UNPACKING AND INSPECTION

- 6.1** This low-voltage disconnect was carefully tested, inspected and packaged for shipment from our factory. Upon receipt of the unit it should be carefully unpacked and inspected for any damage in shipment.
- 6.2** If there is evidence of damage, do not attempt to install the unit. The freight carrier should be notified immediately and a claim for the cost of the unit should be filed with the carrier for direct reimbursement. Be sure to include the model and serial number of the damaged unit in all correspondence with the freight carrier. Also save the shipping carton and packing material as evidence of damage for the freight carrier's inspection.
- 6.3** UNIPOWER will cooperate fully in case of any shipping damage investigation.
- 6.4** Always save the packing materials for later use in shipping the unit. Never ship the LV disconnect without proper packing.

7.0 SPECIFICATIONS

INPUT / OUTPUT

LVD Capacity	400 or 600A Per Load, 800 or 1200A Total
Configuration	Single or Dual LVD
Voltage, ¹ 48V Version	42-59VDC
24V Version	21-29VDC
Polarity	Positive or Negative Ground
LVD Connection	In Series with Battery or Load
LVD Disconnect Voltage ² 48V Version	42.5 VDC
24V Version	21.25 VDC
LVD Reconnect Voltage ² 48V Version	49.0 VDC
24V Version	24.5 VDC

ALARMS

Alarm Connections	Form C Relay Contacts
-------------------------	-----------------------

SAFETY STANDARDS	UL1950, CSA22.2 No.950, EN60-950
-------------------------------	----------------------------------

ENVIRONMENTAL

Operating Temp. Range	-10°C to +50°C
Storage Temp. Range	-40°C to + 85°C
Humidity	0% to 95%, Non-Condensing

PHYSICAL SPECIFICATIONS

Case Material	Steel
Finish	Powder Coat Gray
Rack Mounting Width	19 or 23 Inches
Dimensions, Inches (mm)	3.5 H x 19.00 W x 10.50 D (88.9 x 483 x 267)
.....	3.5 H x 23.00 W x 10.50 D (88.9 x 584 x 267)
Weight, Dual LVD	18 lbs. (8.2 kg.) 3.5 H x 23.00 W x 10.50 D (88.9 x 584 x 267)

CONNECTIONS

Input & Output	5/16-18 Bolts
Chassis Ground Connection	No. 10-32 Stud
Alarm Connections	Miniature Screw Terminals

NOTE: 1. See Ordering Guide to specify voltage.
 2. These voltages are field adjustable.

8.0 SAFETY AND INDUSTRY STANDARDS

8.1 The LVD400/600 Low-Voltage Disconnects meet the following safety certifications:

STANDARD	AGENCY
UL1950	UL
CSA22.2-950	CUL
EN60-950	DEMKO

8.2 The LVD400/600 is CE marked to indicate conformance to the European Union's Low Voltage Directive.

9.0 DESCRIPTION OF OPERATION

9.1 Figure 2 shows a simplified diagram of the LVD400/600 circuit for either the A or B side.

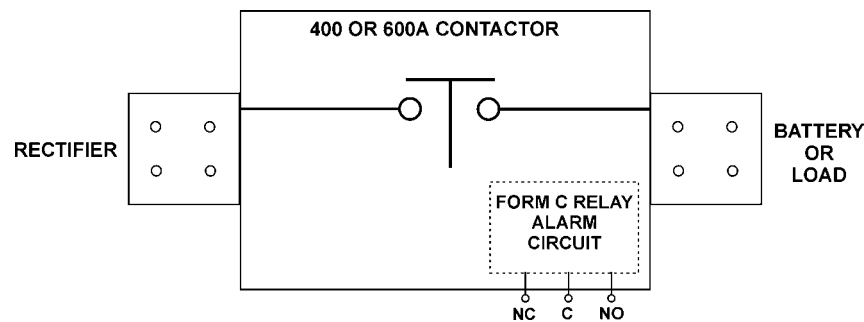

Figure 2. Simplified Diagram of LVD400/600

9.2 The LVD400/600 is connected between the a rectifier and battery or load. The contactor is therefore either in series with the rectifier and load or the rectifier and battery. If the battery voltage drops to approximately 42.5V for a 48V battery or 21.25V for a 24V battery, the contactor opens, removing the load from the rectifier and battery or, alternatively, removing the battery from the rectifier and loads. The disconnect contactor is rated at 400 or 600 amperes (depending on model). See Figures 3 and 4.

9.3 If the contactor opens due to low voltage, it will close again when the battery voltage exceeds approximately 49.0 volts for a 48V battery or 24.5 volts for a 24V battery.

9.4 Other circuitry is incorporated into the LVD400/600 to turn the Form C relay on or off when low battery voltage is detected.

10.0 FRONT PANEL DESCRIPTION

10.1 The front panel comes in two widths for rack mounting: 19 inches or 23 inches. The width is determined by the ordering option. There are no controls or indicators on the front panel.

11.0 BACK PANEL POWER CONNECTIONS

11.1 Back and side views of the LVD400/600 are shown in Figure 3. The LVD400/600 can be connected for either load or battery disconnect.

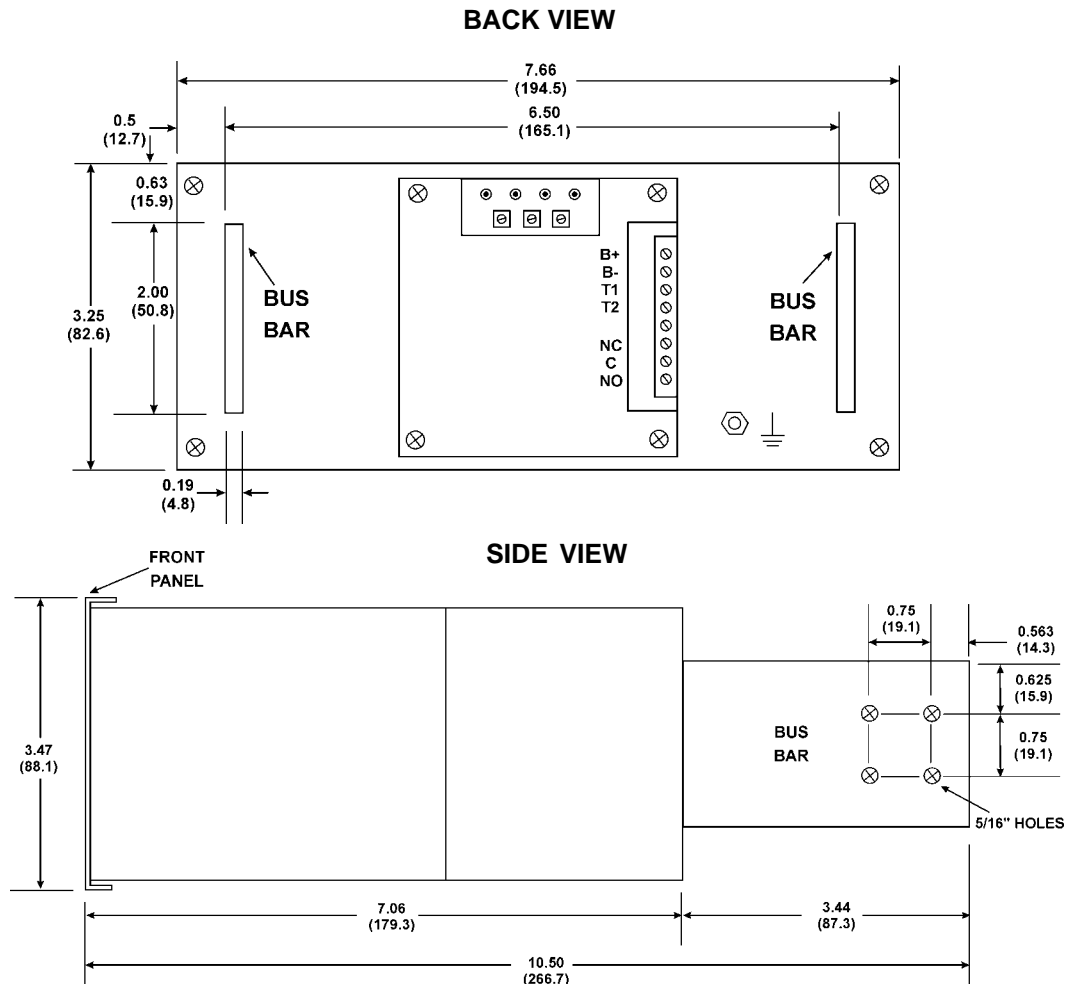

Figure 3. Back and Side Views of LVD400/600

11.2 For load disconnect operation, it is connected between the rectifier and loads. See Fig. 4(a).

11.3 For battery disconnect operation, it is connected between the battery and loads. See Fig. 4(b).

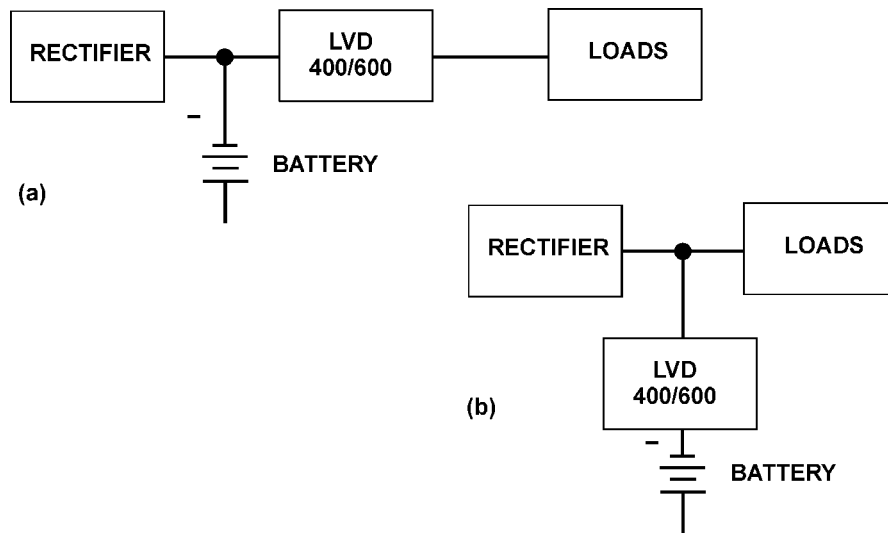

Figure 4. Connections for LVD400/600

12.0 FORM C RELAY CONTACTS

- 12.1** The center of each back panel has connections to the Form C relay contacts for connection to external audible or visual alarm circuits. See Figure 5.

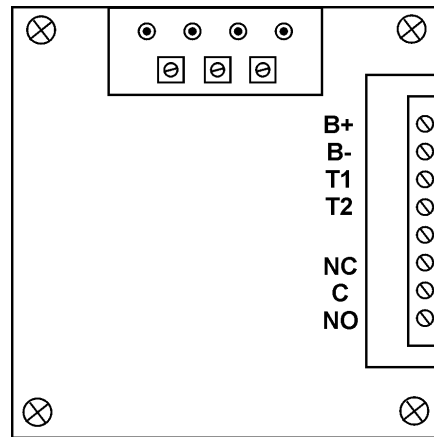

Figure 5. Rear Connections to the LVD400/600.

- 12.2** For each side of the LVD400/600, A or B, there is one set of Form C relay contacts. The contacts are made to miniature screw terminals which are, top to bottom: N.C., C, and N.O.
- 12.3** The Form C relay contacts indicate an alarm condition, i.e., that the LVD contactor is open. “Normally Closed” (N.C.) and “Normally Open” (N.O.) are defined with the LVD400/600 powered and the contactor closed; under these “normal” conditions the relay is energized.
- 12.4** Just below and to the right of the Form C relay terminals is the chassis ground terminal. This terminal is a no. 10-32 stud with nut.

13.0 INSTALLATION

- 13.1 Mounting.** This low-voltage disconnect can be mounted in either a 19- or 23-inch rack depending on model.
- 13.2 Connections.** Power connections should be made to the disconnect bus bars using ¼-inch diameter bolts with nuts. See Figure 4. The Form C relay contact and battery connections are made to the miniature screw terminals. The chassis ground connection is made to the no. 10-32 stud. See Section 12.4. This safety ground connection should be made before operating the panel.
- 13.3 Checking Connections.** Carefully check the correctness of all connections to the LVD400/600 before operating the unit. Reverse connections will not harm the LVD400/600. Check to make sure that the chassis safety ground connection is made. Make sure that all connections are clean and firm to minimize contact resistance.

14.0 SETUP AND TESTING

- 14.1 It is not necessary to have the LVD400/600 mounted in a rack for initial testing. This can be done on a bench. It is not necessary to have loads connected to the LVD400/600 for these tests. Test side A first.
- 14.2 Set an unconnected bench-type DC power supply with digital voltage display to 48VDC if a 48V LVD400/600 is being set up or to 24VDC if a 24V unit is being set up. Turn the power supply off.
- 14.3 Connect the power supply output with correct polarity to the B+ and B- terminals on the back of the LVD using AWG No. 20 copper wire. It is not necessary to make any connection to the bus bars for this test.
- 14.4 Turn the power supply on. You will hear the contactor close. Reduce the power supply output voltage slowly while observing the output voltage. At approximately 42.5V for the 48V version or 21.25V for the 24V version the contactor will open. With an ohmmeter, measure the resistance between the Form C relay terminals C and N.O. It should read a short.
- 14.5 Increase the power supply output voltage slowly while observing the voltage. At approximately 49.0V for the 48V version or 24.5V for the 24V version the contactor will close. With an ohmmeter, measure the resistance between the Form C relay terminals N.C. and C. It should read a short. Turn off the power supply.
- 14.6 Repeat steps 14.2 through 14.5 for the other side (B) of the LVD to test it.
- 14.7 Turn off the power supply and disconnect the wires to the LVD400/600. It is now ready for operation in the telecom system.
- 14.8 If different LVD disconnect and reconnect voltages are desired, they should be set at this time. Call factory for directions on this.

This document is believed to be correct at time of publication and UNIPOWER LLC accepts no responsibility for consequences from printing errors or inaccuracies. Specifications are subject to change without notice.