

DESCRIPTION

UNIPOWER's Sigma Series are 1U x 2U hot-swappable, modular rectifiers & front-ends which produce up to 650 watts output. There are 14 different models with different output voltages and power levels. The modules have automatic load sharing and output ORing diodes so they can be hot-swapped while the system is operating. Module output voltage can be controlled by 0V to +5V analog input.

Green LEDs indicate AC and DC power good. The rectifiers also have control and monitoring features and a +5V standby output. Operating temperature range is -20°C to +70°C.

Companion 19-inch shelves hold up to four modules which can also be operated in a N+1 redundant mode. Single and dual output bus models are available.

FEATURES

- ◆ 1U x 2U Profile: 1.6 x 3.3 Inches
- ◆ -20°C to +70°C Operation
- ◆ 85 to 264VAC or 90 to 420VDC Input
- ◆ Up to 653W Module Output
- ◆ Up to 2612W Shelf Output
- ◆ 0.99 Power Factor
- ◆ Output Voltages: 12 to 54.4VDC
- ◆ 19" Rack/Shelf Holds 4 Units
- ◆ Single or Dual A/B DC Outputs
- ◆ Hot Swappable
- ◆ Integral ORing Diodes
- ◆ Class B EMI Filter
- ◆ Low Noise Variable Speed Fan
- ◆ I²C Serial Data Option
- ◆ 19- or 23-Inch Rack Mounting

THREE YEAR WARRANTY

SAFETY CERTIFICATIONS

UL60950-1 2nd Edition
 CSA22.2, No. 60950-1 2nd Edition
 EN60950-1 2nd Edition

www.unipowerco.com



FRONT-END / RECTIFIER MODULES

MAX. POWER	OUTPUT VOLTAGE	OUTPUT CURRENT	AC INPUT VOLTAGE ¹	AC INPUT CURRENT ²	MODEL NO. ^{3,4}
653W 550W 400W	54.4VDC	12.0A 10.1A 7.4A	85-264VAC	6.5A / 3.2A 5.4A / 2.7A 4.0A / 2.0A	RSJ48/12 RSG48/10 RSF48/7
650W 550W 400W	48.0VDC	13.5A 11.5A 8.3A	85-264VAC	6.4A / 3.2A 5.5A / 2.7A 4.0A / 2.0A	TSJ7000 TSG7000 TSF7000
500W 350W	27.2VDC	18.4A 12.9A	85-264VAC	5.0A / 2.5A 3.5A / 1.7A	RSG24/18 RSF24/13
500W 350W	24.0VDC	20.8A 14.7A	85-264VAC	4.9A / 2.5A 3.5A / 1.7A	TSG5000 TSF5000
450W 300W	13.6VDC	33.0A 22.1A	85-264VAC	4.4A / 2.2A 3.0A / 1.5A	RSG12/33 RSF12/22
450W 300W	12.0VDC	37.5A 25.0A	85-264VAC	4.5A / 2.2A 3.0A / 1.5A	TSG3000 TSF3000

Notes:

1. All units will also operate from 90-420VDC. Consult sales for available 19" power shelf.
2. Input currents shown are nominal values at 120VAC/240VAC as appropriate.
3. To specify I²C Serial Communications append -Z to the model number. Not available with RSF, RSG or RSJ models.
4. To specify chassis-mount version (front-ends only) delete leading T from model number, e.g. TSJ7000 becomes SJ7000.

MODULE ACCESSORIES

DESCRIPTION	PART NUMBER	
	UNIPOWER	POSITRONIC
Mating Connector	354-1665-0000	PCIB24W9F400A1
Evaluation Board	009-3901-0000	

4-BAY 19" SHELF SYSTEM ORDERING GUIDE

MAX. POWER	DESCRIPTION	MAX. CURRENT	MODEL NO.
2612W	Single Output Bus 4 x IEC60320-C14 AC Input	150A	TSGR1U4A
2612W	Dual A/B Output Bus 4 x IEC60320-C14 AC Input	150A	TSGR1U4D

Blanking kit for unused position, order pt. no. 775-1473-0000.

SPECIFICATIONS

Typical at Nominal Line, Full Load and 25°C Unless Otherwise Noted.

INPUT

Voltage Range See Model Table
 Power Factor >0.99
 Total Harmonic Distortion, Max. 5%
 Frequency 47-63Hz
 Inrush Current Limiting, Max. 30A Peak
 EMI Filter, Conducted FCC20780 pt. 15J Curve B
 EN55022 Curve B
 Fast Transients EN61000-4-4
 Surges EN61000-4-5
 Remote Adjust 0 to +5V
 Input Protection ¹ Internal Fuse, 10A

OUTPUT

Current & Voltage See Model Table
 Output Power 300-653W
 Voltage Adjustment Range ±5%
 Standby Output +5V@250mA
 Line & Load Regulation, Max. 2%
 Holdup Time 10msec.
 Overvoltage Protection Latch Off
 Filtering: Wideband Noise, 20MHz BW ²
 48V/54.4V 500mV pk-pk
 24V/27.2V 250mV pk-pk
 12V/13.6V 125mV pk-pk
 Current Limit 105-110% Rated Current
 Efficiency ³ 85-90%

SAFETY

UL60950-1 2nd Ed., CSA22.2 No. 60950-1 2nd Ed.,
 EN60950-1 2nd Ed.

STATUS INDICATORS

AC GOOD Green LED
 DC GOOD Green LED

ALARM SIGNALS (Logic LO, TTL compatible)

ACOK AC present, 5V standby operating
 DCOK DC output within -10% of nominal

SERIAL COMMUNICATIONS

I²C Optional, see selection guide

ENVIRONMENTAL

Operating Temp. Range -20°C to +70°C
 -40°C start-up, reduced performance
 Output Current Derating 2.5%/°C, 50°C to 70°C
 Storage Temp. Range -40°C to + 85°C
 Environment Pollution Degree 2
 Humidity 0% to 95%, Non-Condensing
 ESD Bellcore GR-1089-Core and EN61000-4-2
 MTBF, 35°C (Bellcore) 200,000 Hours
 Cooling Integral Ball Bearing Fan
 Acoustic Noise @ 1m (module) 52-61dB

PHYSICAL SPECIFICATIONS

Case Material Aluminum
 Case Dimensions, Inches (mm) 1.6 H x 3.3 W x 11.0 D
 (40.6 x 83.8 x 279.4)
 Weight 2.1 lbs. (0.95 kg.)

Notes:

- External protection required when operating from HVDC.
- 20MHz bandwidth. Measure with 0.1µF ceramic and 10µF tantalum capacitors in parallel across the output.
- Typical efficiency is at low end of range for 12V output and at high end of range for 48V output.

OUTLINE DRAWING

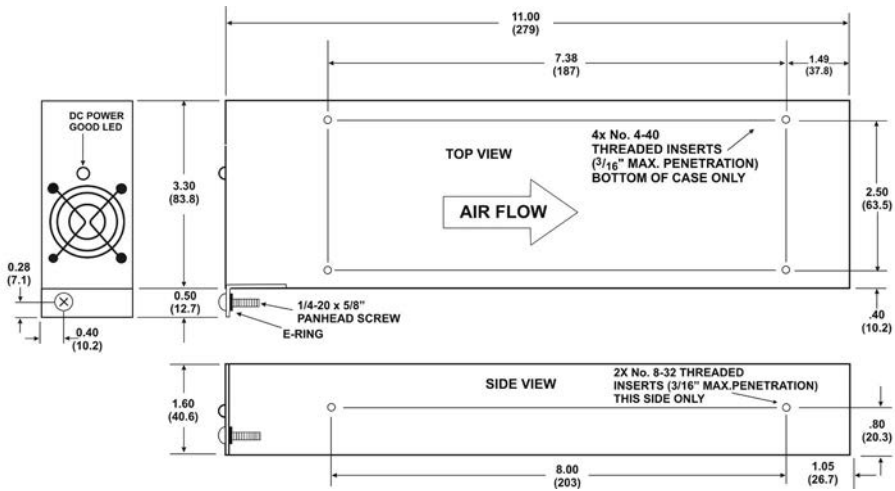

REAR VIEW

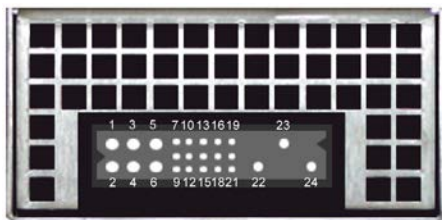

ALL DIMENSIONS IN INCHES (mm).

PIN CONNECTIONS			
PIN	FUNCTION	PIN	FUNCTION
1	+V Out ¹	13	Module Present
2	+V Out ¹	14	GA1 ³
3	V Return ¹	15	AC Power Fail
4	V Return ¹	16	V Trim
5	Sense +Ve	17	Overtemp. Warning
6	Sense -Ve	18	Current Share
7	Enable ²	19	Current Monitor
8	GA2 ³	20	+5V Standby ⁴
9	GA0 ³	21	DC Power Good
10	Inhibit	22	Chassis Ground
11	SDA ³	23	AC Line
12	SCL ³	24	AC Neutral

NOTES:

- For proper operation all +V out pins must be connected together and all V Return pins must be connected together.
- For unit to operate, pin 7 must be at logic LO or shorted to pin 6.
- These pins provide the I²C functions when option -Z is present.
- The +5V standby return is to -Sense (pin 6).
- All signals are referenced to -Sense (pin 6).

I²C SERIAL BUS SPECIFICATIONS

Three forms of data are available via the I²C serial bus, allowing the user to monitor the actual status of an individual unit, manage system loading through measurement of the actual load on the output and also control inventory through an inbuilt EEPROM containing specific data about each individual unit. The implementation of I²C that has been utilized in **Sigma** is a subset of more complete implementations such as IPMI. The following information provides the information required by the system designer to make decisions on how to utilize the available information within his overall system philosophy.

I²C DEVICES EMPLOYED

PCF8574 - An 8-bit digital register manufactured by Philips.

24C02 - A 256 byte EEPROM manufactured by ST.

PCF8591 - A Quad A/D converter manufactured by Philips.

MAX6633 - A 12-bit temperature measurement device manufactured by Maxim.

For detailed information about the operation of these devices please consult the original manufacturers' datasheets.

ELECTRICAL INTERFACE

Addressing (GA0, GA1 and GA2)

Three external address lines are employed allowing up to eight **Sigma** modules to be addressed on a single I²C bus. Module addressing is achieved through hard-wiring the address lines to -Sense or the +5V auxiliary supply via a 100-ohm resistor on the system back-plane. In this way it is the location or position of the module rather than any particular module that is identified by an individual address.

Serial Clock (SCLK)

This line is clocked by the processor which controls the I²C serial bus. It should be tied to +5V via a pull-up resistor in the range 3k to 10k.

Serial Data (SDA)

This line is a bidirectional data line. It should be tied to +5V via a pull-up resistor in the range 3k to 10k.

BUS speed

The I²C interface as used in **Sigma** is designed to run with a serial clock speed 100kHz.

OPERATION AND FUNCTION

Digital Functions

Digital status functions are provided by a PCF8574 8-bit I/O port device. When this device is read by the serial bus controller a single 8-bit word provides the following information:

BIT	FUNCTION	GOOD STATE	MEANING
0	Input Power Fail	0	A "1" provides warning of input supply failure.
1	Output Power Good	0	Vout is within specified limits.
2	Temperature Warning	1	Temperature exceeds normal operating limit.
3	Fan #1 Good	1	Fan running at >80% nominal speed.
4	Fan #2 Good	1	Fan running at >80% nominal speed.
5	-	1	Not used
6	-	1	Not used
7	Temperature Alarm	1	Ambient temperature exceeds 70°C, unit switched off. Also indicates OVP and Inhibit activated.

PCF8527 slave address

BIT	7	6	5	4	3	2	1	0
VALUE	0	1	0	0	A2	A1	A0	R/W

Note: If a zero is written to bit 7 in a data byte, the unit will be inhibited. The default state is enabled.

EEPROM Functions

The EEPROM is a 2048 bit (256 byte) device which is preprogrammed at the factory with the following data:

ADDRESS RANGE	DATA
0-15	Model Number
16-31	Manufacturing Part Number
32-47	Serial Number
48-63	Modification Level
64-79	Manufacturer
80-95	Country of Manufacture
96-255	Not Used

Notes:
Data is organized such that each field of data can be accessed by a page read (16 bytes).

Customers may specify other data to special order.

EEPROM slave address

BIT	7	6	5	4	3	2	1	0
VALUE	1	0	1	0	A2	A1	A0	R/W

Analogue Functions

Analogue status functions are provided by two PCF8591 4-channel 8-bit A/D converter devices. When these devices are read by the serial bus controller a single 8-bit word provides the following information:

Device: U1			
A/D	FUNCTION	A/D	FUNCTION
1	Vout voltage	3	not used
2	Vout current	4	not used

PCF8591 slave address

BIT	7	6	5	4	3	2	1	0	Device
VALUE	1	0	0	1	A2	A1	A0	R/W	U1

The PCF8591 devices initially require a control byte (04 Hex) to be written to the configuration register. This control byte sets the device so that on each successive read the data from the next A/D is read. Note that on each read a conversion is started for a particular channel and the result will be read from the previous channel, thus the first result from a sequence of reads should always be discarded.

A/D Converter Scaling

To obtain a correct voltage or current measurement it is necessary to employ a scaling factor in the controlling software. Note that all voltage measurements are made inside the PSU module, before the 'ORing' diodes, and are typically 0.5V higher than the actual module output voltage. The following calculation should be employed:

$$\text{Value} = (\text{byte read} \times \text{scaling factor})$$

Output Voltage	Scaling	Tolerance	
48V	0.24	±2%	V Measure (U1 A/D Chan. 1)
48V	0.125	±10% *	I Measure (U1 A/D Chan. 2)

* percentage of full scale

Temperature Measurement Functions

The internal temperature of the unit is measured using a MAX6633. This device provides a 12-bit measurement at a resolution of 0.0625°C.

MAX6633 slave address

BIT	7	6	5	4	3	2	1	0
VALUE	1	0	0	0	A2	A1	A0	0

SPECIFICATIONS, RACKS/SHELVES

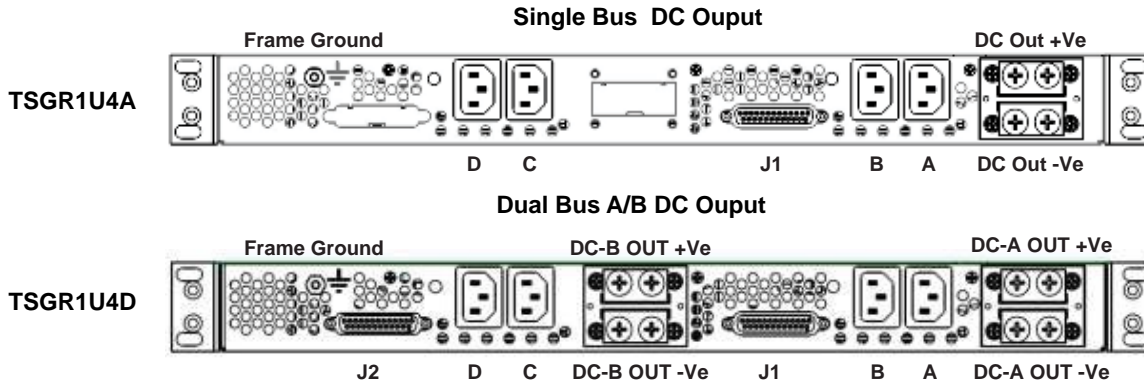
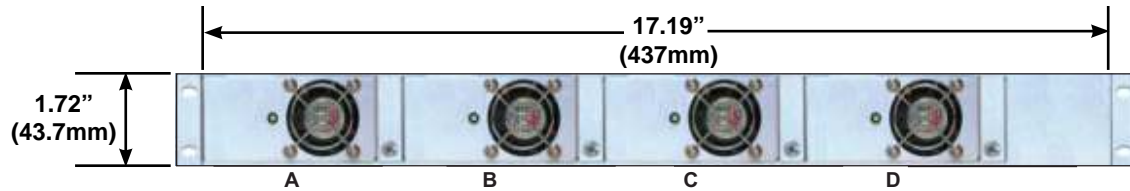

NOTES:

1. Rack/shelf depth is 13.88" (353mm). Weight is 9.0lbs (4.1kg).
2. There are plastic safety covers over the DC output bus bars.

NOTES:

1. All electrical connections are made to the rear of the rack. There is one AC inlet for each module. Connector A goes to module A, connector B to module B, connector C to module C and connector D to module D.
2. Module A is on the left, module B in the center left, module C in the centre right and module D is on the right as seen from the rack front.
3. For TSGR1U4A the outputs of all modules are connected in parallel in the rack. For TSGR1U4D the outputs of modules A & B are connected for the DC-A output and modules C & D are connected for the DC-B output.
5. The input voltage range is 85-264 for maximum power in either redundant or non-redundant operation.
6. The Module Present outputs (J4 pins 20, 21 and 22) are grounded (to -Sense) when the module is plugged in and open when the module is out.
7. Protective covers are provided as standard for the DC output terminals.
8. For HVDC input applications consult sales.

CONNECTIONS

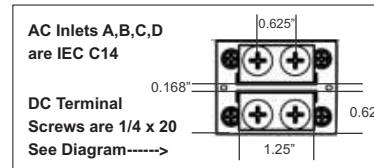

MAXIMUM OUTPUT CAPACITY - 4 MODULES

MODULES	NON-REDUNDANT	3+1 REDUNDANT
RSG12/33	13.6VDC @ 132.0A 1800W	13.6VDC @ 99.0A 1350W
RSG24/18	27.2VDC @ 73.6A 2000W	27.2VDC @ 55.2A 1500W
RSJ48/12	54.4VDC @ 48.0A 2611W	54.4VDC @ 36.0A 1958W
TSG3000	12.0VDC @ 150.0A 1800W	12.0VDC @ 112.5A 1350W
TSG5000	24.0VDC @ 83.2A 2000W	24.0VDC @ 62.4A 1500W
TSJ7000	48.0VDC @ 54.0A 2611W	48.0VDC @ 40.8A 1958W

J1 / J2 CONNECTION DETAILS

SIGNAL CONNECTOR SINGLE BUS - J1			
PIN	FUNCTION	PIN	FUNCTION
1	Inhibit	14	AC Power Fail - A
2	Not used	15	DC Power Good - A ¹
3	Overtemp. Warning - A ¹	16	AC Power Fail - B
4	Overtemp. Warning - B ¹	17	DC Power Good - B ¹
5	Overtemp. Warning - C ¹	18	AC Power Fail - C
6	Overtemp. Warning - D ¹	19	DC Power Good - C ¹
7	Remote Adjust - D	20	AC Power Fail - D
8	5V Standby ²	21	DC Power Good - D ¹
9	SDA	22	Sense -Ve
10	Current Share	23	Sense -Ve
11	Sense +Ve	24	Remote Adjust - A
12	Remote Adjust - B	25	Remote Adjust - C
13	SCLK		

SIGNAL CONNECTOR DUAL BUS - J1 or J2			
PIN	FUNCTION	PIN	FUNCTION
1	Inhibit	14	AC Power Fail - A or C
2	Not used	15	DC Power Good - A or C ¹
3	Overtemp. Warning - A or C ¹	16	AC Power Fail - B or D
4	Overtemp. Warning - B or D ¹	17	DC Power Good - B or D ¹
5	Not used	18	Not used
6	Not used	19	Not used
7	Not used	20	Not used
8	5V Standby ²	21	Not used
9	SDA	22	Sense -Ve
10	Current Share	23	Sense -Ve
11	Sense +Ve	24	Remote Adjust - A or C
12	Remote Adjust - B or D	25	Not used
13	SCLK		

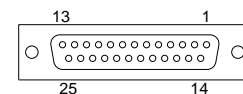

25-way D-type Socket

SHIPPING WEIGHTS
Shelf: 12.0 lbs. (5.5Kg)
Modules: 4.0 lbs. (1.8Kg)









SHIPPING DIMENSIONS

Shelf: 22" (559mm) x 22" (559mm) x 3" (76mm)
Module: 15" (381mm) x 8" (203mm) x 4" (102mm)















NOTES:

1. These pins are open when the IFC option is fitted.
2. Referenced to Sense -Ve.

ALARM & COMMUNICATIONS ADAPTORS

RELAY ALARM ADAPTOR Part No.: 009-1005-0000 009-1013-0000 (with voltage trim)		Datasheet WEB Link	Notes
	Plugs directly into the 25 way D-Type signal connector J1 (J2) and converts DC good signal for each module to a Form-C volts-free relay contact output. The module allows daisy chaining of parallel connected shelves for share bus and remote sense. Part No. 009-1013-0000 includes an output voltage trim facility. NOTE: Compatible only with single bus model TSGR1U4A.		
SNMP ALARM TRAP ADAPTOR Part No.: 009-1006-0000		Datasheet WEB Link	Notes
	Plugs directly into the 25 way D-Type signal connector J1 (J2). Monitors DC Good signal of each power module. Plugs directly into the 25 way DType signal connector J1 (J2). Monitors DC Good signal of each power module. When an alarm occurs or clears a built-in processor sends an SNMP alarm trap to the monitoring host and can send an email message. Allows daisy chaining of parallel connected shelves for share bus and remote sense connections. NOTE: Compatible only with single bus models TBSR1U4A and TBSR1U4B.		MIB files (.exe)  Setup guide 
MODULE EVALUATION BOARD Part No.: 009-3901-0000		SIGMA Manual WEB Link	Notes
	Plugs directly into the Sigma module connector to provide industrial connections for testing and evaluation. Provides AC in and DC out plus alarm connections. 2 LEDs: AC good, DC good.		See page 11 Fig. 5 for details.

AC CORDS & DC CABLES

AC LINE CORDS - 120V 15A Part No.: 364-1412-0000	NEMA 5-15	IEC-C13
One cord per power module for TSGR1U4A or TSGR1U4D shelf. Cord length 6ft (1.83m)		
AC LINE CORDS - 240V 15A Part No.: 364-1414-0000	NEMA 6-15	IEC-C13
One cord per power module for TSGR1U4A or TSGR1U4D shelf. Cord length 6ft (1.83m)		
AC LINE CORDS - 120/240V 15A Part No.: 364-1421-0000	ROJ-LEADS	IEC-C13
One cord per power module for TSGR1U4A or TSGR1U4D shelf. Cord length 6ft (1.83m) REQUIRES CUSTOMER SUPPLIED PLUG		
DC CABLE KIT - 1 to 1 LUG 30" Part No.: 775-1497-1130	Start Lug	End Lug
Pair of Black / Red #4AWG copper cable (600V 125A) 30" (76cm) with lug terminations and heat shrink. Single hole both ends. Hole size 0.25", tongue width 0.55".		
DC CABLE KIT - 1 to 1 LUG 84" Part No.: 775-1497-1184	Start Lug	End Lug
One pair Black / Red #4AWG copper cable (600V 125A) 84" (213cm) with lug terminations and heat shrink. Single hole both ends. Hole size 0.25", tongue width 0.55"		
DC CABLE KIT - 1 to 2 LUG 30" Part No.: 775-1497-1230	Start Lug	End Lug
Pair of Black / Red #4AWG copper cable (600V 125A) 30" (76cm) with lug terminations and heat shrink. Single hole one end, two hole one end. Hole size 0.25", tongue w = 0.55", spacing 0.625"		
DC CABLE KIT - 1 to 2 LUG 84" Part No.: 775-1497-1284	Start Lug	End Lug
One pair Black / Red #4AWG copper cable (600V 125A) 84" (213cm) with lug terminations and heat shrink. Single hole one end, two hole one end. Hole size 0.25", tongue width 0.55", spacing 0.625"		
DC CABLE KIT - 2 to 2 LUG 30" Part No.: 775-1497-2230	Start Lug	End Lug
One pair Black / Red #4AWG copper cable (600V 125A) 30" (76cm) with lug terminations and heat shrink. Two hole both ends. Hole size 0.25", tongue width 0.55", spacing 0.625"	