

DESCRIPTION

UNIPower's **SSD3000** is a new generation of high density hot-swap Front-Ends for Networking and DataCom applications that utilize the 12V Bus Architecture. With a high power density and efficiency of 85% (minimum), these "GREEN" power solutions help system designers satisfy increasing demands for reduced energy consumption, smaller size and reduced costs.

These 280 Watt Power Modules feature communication for status and control of each power module with front panel LED indicators to communicate status or fault conditions. N+1 Redundant operation is achieved with active load sharing and ORing protection circuits.

FEATURES

- ◆ 85% Efficiency (minimum)
- ◆ 1U High: 1.57"
- ◆ 0°C to +40°C Operation (Full Load)
- ◆ Universal AC Input
- ◆ >0.95 Power Factor (minimum)
- ◆ Output Voltages: 12VDC, -12V & 5VSB
- ◆ Power Density to >10W/in³
- ◆ Hot Swappable
- ◆ Integral Active Output ORing Circuit
- ◆ Class B EMI Filter
- ◆ LED Indicators
- ◆ Variable Speed Cooling Fans

TWO-YEAR WARRANTY

INTERNATIONAL STANDARDS

UL/cUL 60950-1, TUV EN 60950-1
CB IEC 60950-1, WEEE, CE Mark (LVD)



12V FRONT END MODULE

POWER	+12V _{OUT}	-12V _{OUT}	5V _{SB}	MODEL NO.
280W	22A	0.5A	2A	SSD3000

* Total power May Not Exceed 280 Watts

1. Purpose

This specification defines the performance characteristics and functions of a 280 watts 1U form factor of switching mode power module with Active PFC (Power Factor Correction).

2. AC Input Requirements

2.1 Input Voltage and Frequency

Voltage (sinusoidal) : 100~240 VAC full range, with $\pm 10\%$ tolerance. Frequency ranges from 47hz~63hz

2.2 AC Input Current and Inrush Current

AC line inrush current shall not damage any component nor cause the AC line fuse to blow under any DC conditions and with any specified AC line input voltage and frequency. Repetitive On/Off cycling of the AC input voltage shall not damage the power supply.

Table 1: AC Input Current and Inrush Current

Parameter	Minimum	Rated	Maximum	Max. Current	Inrush Current
Voltage (115V)	90 Vac	100-127Vac	132 Vac	4A	35A@115VAC
Voltage (230V)	180 Vac	200-240Vac	264Vac	2A	70A@230VAC

2.3 Input Power Factor Correction (Active PFC)

The power factor at 100% of rated load shall be ≥ 0.95 at nominal input voltage.

2.4 AC Line Transient Specification

AC line transient conditions are characterized as “sag” and “surge” conditions. Sag conditions (also referred to as “brownout” conditions) will be defined as the AC line voltage dropping below nominal voltage. Surge conditions will be defined as the AC line voltage rising above nominal voltage. The power supply shall meet the regulation requirements under the following AC line sage and surge conditions.

Table 2: AC Line Sag Transient Performance

Duration	Sag	Operating AC Voltage	Line Frequency	Performance Criteria
Continuous	10%	Nominal AC Input ranges	50/60 Hz	No loss of function or performance
0-1 AC cycle	100%	Nominal AC Input ranges	50/60 Hz	No loss of function or performance
> 1 AC cycle	> 10%	Nominal AC Input ranges	50/60 Hz	Loss of function Acceptable,

Table 3: AC Line Surge Transient Performance

Duration	Surge	Operating AC Voltage	Line Frequency	Performance Criteria
Continuous	10%	Nominal AC Voltage	50/60 Hz	No loss of function or performance
0 - ½ AC cycle	30%	Mid-point of Nominal AC Voltage	50/60 Hz	No loss of function or performance

3. DC Output Specification

3.1 Output Power / Currents

Table 4: Load Range

Voltage	Minimum Continuous Load	Maximum Continuous Load ^{1,3}
+12V	0.8A	22A
-12V	0A	0.5A
+5VSB	0A	2A

Notes: The total combined outputs shall not exceed 280W.

3.2 Voltage Regulation, Ripple and Noise

Table 5: Regulation, ripple and noise

Output Voltage	+12V	-12V	+5VSB
Load Reg.	±5%	±5%	±5%
Line Reg.	±1%	±1%	±1%
Ripple & Noise	120mV	120mV	60mV

Ripple and noise shall be measured using the following methods:

- Measurements made differentially to eliminate common-mode noise
- Ground lead length of oscilloscope probe shall be ≤ 0.25 inch.
- Measurements made where the cable connectors attach to the load.
- Outputs bypassed at the point of measurement with a parallel combination of 10uF tantalum capacitor in parallel with 0.1uF ceramic capacitors.
- Oscilloscope bandwidth of 0 Hz to 20MHz.
- Measurements measured at locations where remote sense wires are connected.
- Regulation tolerance shall include temperature change, warm up drift and dynamic load

3.3 Capacitive Loading

The power supply shall be stable and meet all requirements in the following table, except dynamic loading requirements.

Table 6: Capacitive Loading Conditions

Output	MIN	MAX	Units
+12V	10	6,800	uF
-12V	1	350	uF
+5VSB	1	350	uF

3.4 Dynamic Loading

The output voltages shall remain within the limits specified in **Table-Regulation, ripple and noise** for the step loading and within the limits specified in **Table-Transient Load Requirement** for the capacitive loading.

The load transient repetition rate shall be tested between **50Hz and 5kHz** at duty cycle ranging from

10%-90%. The load transient repetition rate is only a test specification. The Δ step load may occur anywhere within the MIN load to the MAX load shown in **Table-Load Range**.

Table 7: Transient Load Requirements

Output	Δ Step Load Size	Load Slew Rate	Capacitive Load
+12V	65% of Max. Load	0.5 A/uS	2200 uF
+5VSB	30% of Max. Load	0.5 A/uS	1 uF

3.5 Overshoot at Turn-on/Turn-off

Any output overshoot at turn on shall be less than 10% of the nominal output value. Any overshoot shall recover to be within regulation requirements in less than 10ms.

3.6 Timing Requirements

Table 8: Output Voltage Timing

Item	Description	MIN	MAX	Units
Tvout_rise	Output voltage rise time from each main output	1	25	mS
	Output voltage rise time for the 5Vsb out put	1	25	mS
Tvout_on	All main output must be within regulation of each other within this time.		50	mS
Tvout_off	All main output must leave regulation within this time		400	mS

Table 9: Turn On/Off Timing

Item	Description	MIN	MAX	Units
Tsb_on-delay	Delay from AC being applied to +5VSB being within regulation.		1500	mS
Tac_on-delay	Delay from AC being applied to all output voltages being within regulation.		2500	mS
Tvout_holdup	Time all output voltage stay within regulation after loss of AC tested at 80% of maximum load.	18		mS
Tpwok_holdup	Delay from loss of AC deassertion of PWOK tested at 80% of maximum load.	17		mS
Tpson_on_delay	Delay from PSON# active to output voltage within regulation limits.	5	400	mS
Tpson_pwok	Delay from PSON# deactive to PWOK being deasserted.		50	mS
Tpwok_on	Delay from output voltage within regulation limits to PWOK asserted at turn on.	100	1000	mS
Tpwok_off	Delay from PWOK deasserted to output voltages dropping out of regulation limits.	1		mS
Tpwok_low	Duration of PWOK being in the deasserted state during an off/on cycle using AC or the PSON# signal. .	100		mS
Tsb_vout	Delay from +5VSB being in regulation to O/Ps being in regulation at AC turn on.	50	1000	mS

Figure 1: Turn On/Off Timing

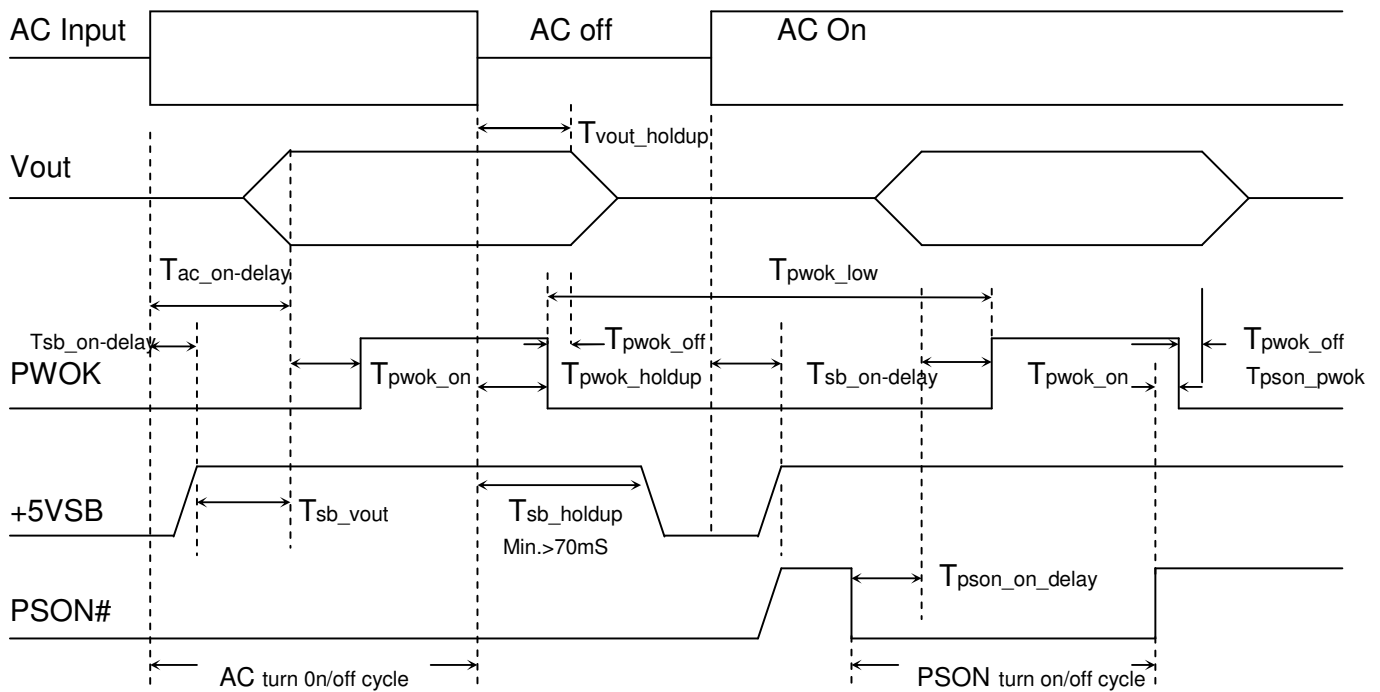

3.7 Efficiency

The minimum power supply system efficiency shall be 85%, measured at nominal input voltage 230 V with outputs 12V/22A and 5VSB/0.5A

4. Protection Circuits

Protection circuits inside the power supply shall cause only the power supply's main outputs to shutdown. If the power supply latches off due to a protection circuit tripping, an AC cycle OFF for 15 sec and a PSON# cycle HIGH for 1 sec must be able to restart the power supply.

4.1 Over Current Protection (OCP)

The power supply shall have current limit to prevent the +5V, +3.3V, and +12V outputs from exceeding the values shown in **Table-Over Current Protection**. The power supply shall latch off if the current exceeds the limit.

Table 10: Over Current Protection

Voltage	Minimum	Maximum	Shutdown Mode
+12V	24A	35A	Latch Off

4.2 Over Voltage Protection (OVP)

The power supply shall shut down and latch off after an over voltage conditions occurs.

Table 11: Over Voltage Protection

Voltage	Minimum	Maximum	Shutdown Mode
+12V	+13.2V	+14.5V	Latch Off

4.3 Short Circuit Protection

The power supply shall shut down in latch off mode when the output voltage is short circuit.

4.4 No Load Operation

No damage or hazardous condition should occur with all the DC output connectors disconnected from the load. The power supply may latch into the shutdown state.

4.5 Over Temperature Protection (OTP)

The power supply will shut down when an over temperature condition occurs; no damage shall be caused.

5. Environmental Requirements

5.1 Temperature

Operating Ambient: 0°C ~ 40°C (32°F~ 104°F)

Non-operating Ambient:: -40°C ~ 70°C (-40°F~ 158°F)

5.2 Humidity

Operating: 20% ~ 90%RH non-condensing

Non-Operating: 5% ~ 95%RH non-condensing

5.3 Altitude

Operating: Sea level to 10,000 ft

Non Operating: Sea level to 40,000 ft

5.4 Mechanical Shock

Non-Operating: 50 G Trapezoidal Wave, 11mS half sin wave. The shock is to be applied in each of the orthogonal axes.

5.5 Vibration (Non-Operating)

The power supply shall be subjected to a vibration test consisting of a 10 to 300 Hz sweep at a constant acceleration of 2.0g for duration of one (1) hour for each of the perpendicular axes X, Y and Z (0.1 octave/minute). The output voltages shall remain within specification.

5.6 Electromagnetic Compatibility

Table 12: EMC Requirements

Electromagnetic Interference	FCC CFR Title 47 Part 15 Sub Part B EN55022/EN55024	Conducted B Class Radiated A Class		
Harmonics	IEC61000-3-2 Class D			
Flicker	IEC61000-3-3			
ESD Susceptibility	EN-61000-4-2	±8KV by Air, ±4KV by Contact Performance Criteria B		
Radiated Susceptibility	EN61000-4-3	80MHz~1000MHz (3V/m(mns) Amplitude 80% AM 1KHz Criteria A		
EFT/Burst	EN61000-4-4	5KHz, AC: 1KV, DC: 0,5 KV, Performance Criteria B		
Surge Voltage	EN61000-4-5	Line-to-Line: 1KV Line-to-Ground: 2KV Performance Criteria B		
Conducted Susceptibility	EN61000-4-6	0.15MHz~80MHz 3V/m Amplitude 80% AM 1KHz Performance Criteria A		
RF Conducted	EN61000-4-8	50 Hz/3A(ms)/m Performance Criteria A		
Voltage Dips and Interruptions	EN61000-4-11	30%(Voltage Dips)	10 ms	Criteria B
		60%(Voltage Dips)	100ms	Criteria C
		>95%(Voltage Dips)	500ms	Criteria C
Leakage Current	EN60950-1	3.5mA@250VAC		

5.7 Safety Agency Requirements

This power supply is designed to meet the following safety

Table 13: Product Safety

Product Safety:	UL,cUL	UL60950-1
	CB	IEC60950-1
	TUV	EN60950-1
	CCC	

6 Reliability

6.1 Mean Time Between Failures (MTBF)

The MTBF of the power supply shall be calculated utilizing the Part-Stress Analysis method of MIL217F. The calculated MTBF of the power supply shall be greater than 200,000 hours under the following conditions:

Full rated load; 120V AC input; Ground Benign; 25°C

7. LED Indicators

There will be a LED on each power module to indicate power status

Table 14: LED Color and Power Status

Power Supply Status	Color
Works Normally	Green
Standby (Only +5VSB output)	Amber
Power Fail	Red
Fan Fail	Red

8. Output Pin Assignment

Table 15: Output Pin Assignment

TOP SIDE		BOTTOM SIDE	
PIN#	SIGNAL	SIGNAL	PIN#
59	ACL	ACL	60
57	X	X	58
55	X	X	56
53	X	X	54
51	ACN	ACN	52
49	X	X	50
47	X	X	48
45	X	X	46
43	GND	GND	44
41	GND	GND	42
39	GND	12V	40
37	GND	12V	38
35	GND	12V	36
33	GND	12V	34
31	GND	12V	32
29	GND	12V	30
27	GND	12V	28
25	GND	12V	26
23	GND	12V	24
21	GND	12V	22
19	GND	12V	20
17	GND	12V	18
15	GND	12V	16
13	-12V	+5VSB	14
11	5VSB_VS	+5VSB	12

9	EN	12RS+	10
7	X	PSON	8
5	X	PG	6
3	SMB_ALERT	X	4
1	Present	PS_KILL	2

Table 16: Output Pin Definition

Pin Name	Function Description	Note
ACL	AC Input - Line	For front AC access
X	NC	
ACN	AC Input - Neutral	
GND	Grounding	
12V	12V Output	
-12V	-12V Output	
+5VSB	5VSB Output	
5VSB_VS	5VSB Remote sense(+)	
12RS+	12V Remote sense(+)	
EN	PDB ot Module LED Control	Connect pin to pin at backplane with PS_ON
PSON	Power ON Control (Low = POWER ON)	
PG	POWER GOOD Signal	
SMB_ALERT	Power Fail signal (Normal = High)	AC Loss , Power Fail , Fan Fail = Low
PS_KILL	Activate PSU by hot-plug activity	
Present	This pin is grounded with a 47R resistor. To indicate a power has been plugged in.	

10. Mating Connector Specification

10.1 Input Power Connector

SSD3000 uses an IEC C14 inlet

10.2 Output Power Connector

1.27mm pitch card edge connector or equivalent

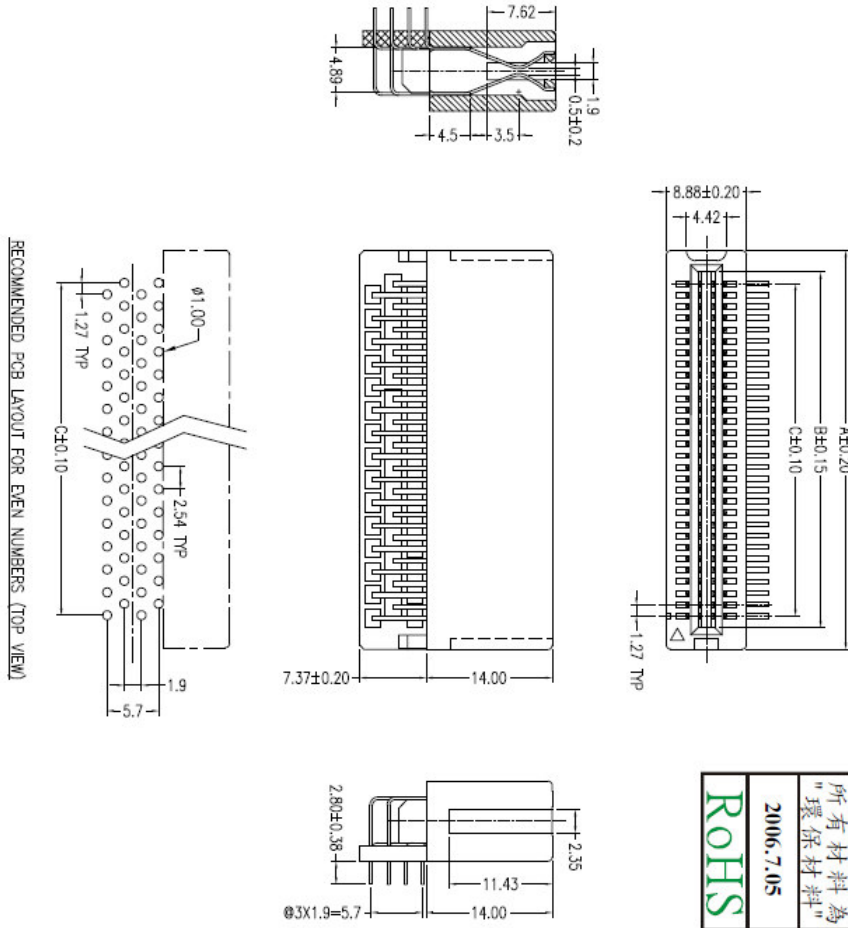

Circuit	Dimension			Circuit	Dimension		
	A	B	C		A	B	C
04	8.64	3.81	1.27	38	30.23	25.40	22.86
06	9.91	3.08	2.54	40	31.50	26.67	24.13
08	11.18	6.35	3.81	42	32.77	27.94	25.40
10	12.45	7.62	5.08	44	34.04	29.21	26.67
12	13.72	8.89	6.35	46	35.31	30.48	27.94
14	14.99	10.16	7.62	48	36.58	31.75	29.21
16	16.26	11.43	8.89	50	37.85	33.02	30.48
18	17.53	12.70	10.16	52	39.12	34.29	31.75
20	18.80	13.97	11.43	54	40.39	35.56	33.02
22	20.07	15.24	12.70	56	41.66	36.83	34.29
24	21.34	16.51	13.97	58	42.93	38.10	35.56
26	22.61	17.78	15.24	60	44.20	39.37	36.83
28	23.88	19.05	16.51	80	56.90	52.07	49.53
30	25.15	20.32	17.78	100	69.60	64.77	62.23
32	26.42	21.59	19.05	120	82.30	77.47	74.93
34	27.69	22.86	20.32				
36	28.96	24.13	21.59				

ENVIRONMENTAL
 TEMPERATURE RANGE: -55°C TO +85°C.

MECHANICAL
 RETENTION FORCE: 460 GRAMS MIN PER CONTACT.
 INSERTION FORCE: 230 GRAMS MAX PER CONTACT PAIR.
 WITHDRAWAL FORCE: 15 GRAMS MIN PER CONTACT PAIR.

ELECTRICAL
 VOLTAGE RATING: 250 VAC RMS.
 CURRENT RATING: 1 AMP.
 DIELECTRIC WITHSTANDING VOLTAGE: 500 VAC RMS 60HZ
 FOR 1 MINUTE
 INSULATION RESISTANCE: 1000 MEGOHMS MIN AT 500 VDC.
 CONTACT RESISTANCE: 30 MILLIOHMS MAX.

MATERIAL
 INSULATOR: GLASS-REINFORCED THERMOPLASTIC.
 CONTACT: COPPER ALLOY.
 PLATING: MATING AREA - GOLD FLASH GOLD OVER NICKEL.
 SOLDER AREA - TIN OVER NICKEL.

11. Mechanical Overview

Dimension: 50.5mm(W) x 40mm(H) x 220mm(D)

Weight: Under 2 Kg

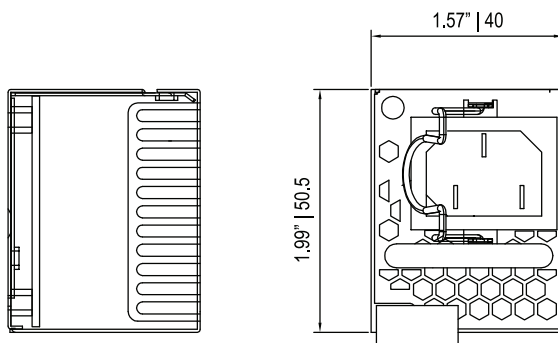
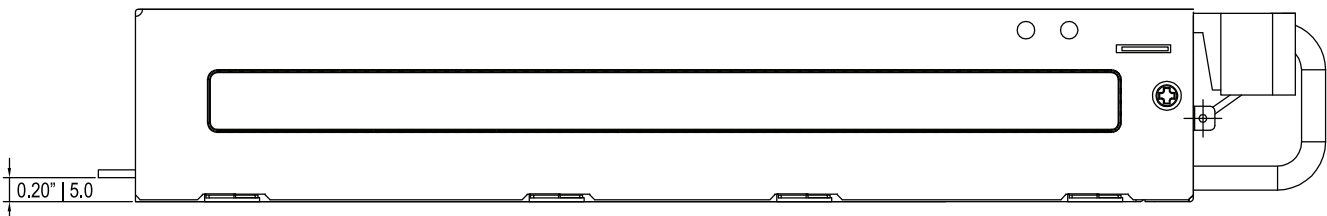
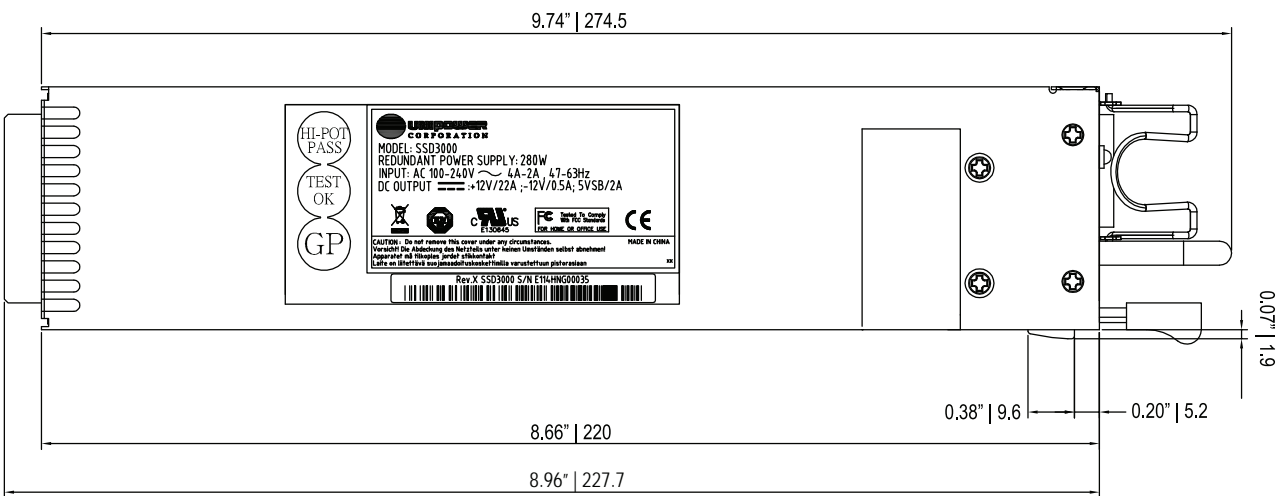
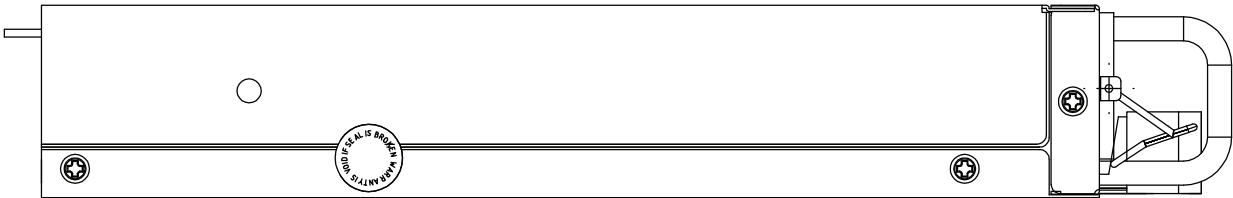

UNIT: Inches | mm

© 2013 UNIPOWER LLC

This document is believed to be correct at time of publication and Unipower LLC accepts no responsibility for consequences from printing errors or inaccuracies. All specifications subject to change without notice.

© 2014 UNIPOWER LLC

This document is believed to be correct at time of publication and Unipower LLC accepts no responsibility for consequences from printing errors or inaccuracies. All specifications subject to change without notice.